



# Heatless Desiccant Dryer User Manual

Models TW0055 - TW3000



ENGINEERING **YOUR** SUCCESS.

## Table of Contents

Section	Section Description	Page
1.0	Introduction	2
2.0	Safety Information	3
3.0	Description	4
3.1	Optional Filter Packages Available	4
3.2	Stages of Purification	4
3.3	How to Order	5
3.4	Technical Specifications	5
3.5	Product Selection & Correction Factors	5
3.6	Weights and Dimensions	6
4.0	Receiving And Inspecting the Equipment	7
5.0	General Operation	10
6.0	Installation and Startup	11
7.0	Basic/Basic Plus Controls Manual	12
8.0	Advanced Controls Manual	23
9.0	Operation	24
10.0	Settings	27
11.0	Filters	31
12.0	Loss of Power	32
13.0	Low System Pressure	32
14.0	Sensor Range and Offset Settings	33
15.0	System Settings	34
16.0	Alarms	35
17.0	Trends and Datalogs	40
18.0	Modbus Communications	41
19.0	Voice of the Machine	50
20.0	Maintenance Intervals	50
21.0	Maintenance Kits	51
22.0	Spare Parts Lists	52
23.0	Drawings	57
24.0	Schematics	64
25.0	Flow Drawings	72
26.0	Troubleshooting	76



## 1.0 INTRODUCTION

These instructions must be thoroughly read and understood before installing and operating this product. Failure to operate this product in accordance with the instructions set forth in this manual can lead to unsafe operating conditions and may void warranty. For additional information, refer to this manual or contact the factory for recommendations. Please have the dryer serial number and model ready when contacting the factory.

This product contains proprietary software. Access to the software is not permitted for any reason without express written approval of Parker Hannifin.

### Factory Contact Information

Phone: 1-800-343-4048

- Press 1 for General Inquiries
- Press 2 for Technical Support

For pricing, availability, and purchase orders:

- [IGFG.Orders@support.parker.com](mailto:IGFG.Orders@support.parker.com)

For technical support and aftermarket:

- [IGFG.Support@support.parker.com](mailto:IGFG.Support@support.parker.com)

For product applications and technical sales: [FAFQuotes@parker.com](mailto:FAFQuotes@parker.com)

## 2.0 SAFETY INFORMATION

Do not operate this equipment until the safety information and instructions in this user guide have been read and understood by all personnel concerned.

### USER RESPONSIBILITY

FAILURE OR IMPROPER SELECTION OR IMPROPER USE OF THE PRODUCTS DESCRIBED HEREIN OR RELATED ITEMS CAN CAUSE DEATH, PERSONAL INJURY AND PROPERTY DAMAGE.

This document, and other information from Parker Hannifin Corporation, its subsidiaries or authorized distributors, provide product or system options for further investigation by users having technical expertise.

The user, through its own analysis and testing, is solely responsible for making the final selection of the system and components and assuring that all performance, endurance, maintenance, safety and warning requirements of the application are met. The user must analyze all aspects of the application, follow applicable industry standards, and follow the information concerning the product in the current product catalogue and in any other materials provided from Parker.

To the extent that Parker, its subsidiaries, or authorized distributors provide component or system options based upon data or specifications provided by the user, the user is responsible for determining that such data and specifications are suitable and sufficient for all applications and reasonably foreseeable uses of the components or systems.

Only competent personnel trained, qualified, and approved by Parker Hannifin should perform installation, commissioning, service, and repair procedures.

Use of the equipment in a manner not specified within this user guide may result in an unplanned release of pressure, which may cause serious personal injury or damage.

When handling, installing, or operating this equipment, personnel must employ safe engineering practices and observe all related regulations, health & safety procedures, and legal requirements for safety.

Ensure that the equipment is depressurized and electrically isolated, prior to carrying out any of the scheduled maintenance instructions specified within this user guide.

Parker Hannifin cannot anticipate every possible circumstance which may represent a potential hazard. The warnings in this manual cover the most known potential hazards, but by definition cannot be all-inclusive. If the user employs an operating procedure, item of equipment or a method of working which is not specifically recommended by Parker Hannifin the user must ensure that the equipment will not be damaged or become hazardous to persons or property.

Most accidents that occur during the operation and maintenance of machinery are the result of failure to observe basic safety rules and procedures. Accidents can be avoided by recognizing that any machinery is potentially hazardous.

Should you require any technical support or training on this equipment, or any other equipment within the Parker Hannifin range, please contact Parker Hannifin Corporation.



### 3. DESCRIPTION

Parker TW Series Heatless Desiccant Compressed Air Dryer packages are designed to filter and dehumidify compressed air to quality levels in accordance with the most widely used international standard, ISO8573-1. These all-inclusive compressed air treatment packages can be factory mounted or shipped loose to the customer. It is always recommended to have at minimum a 0.01 Micron coalescing filter at the inlet of the desiccant dryer & a 1 Micron particulate filter at the outlet of the desiccant dryer, additional filtration can be installed upstream & downstream of the dryer.

With options for 3 different filter packages, the entire dryer package is designed to remove harmful compressed air contaminants that could cause machine downtime downstream. These contaminants include: atmospheric particles, rust, pipe scale, microorganisms, water aerosols and oil aerosols. Following pre-filtration, the compressed air enters a twin tower desiccant dryer. Desiccant dryers remove water vapor and deliver a constant pressure dewpoint of -40°F (-40°C) or better to downstream equipment and/or processes. Once dried, the compressed air flows through a dry particulate after-filter to capture any desiccant dust that may attempt to flow downstream.

#### 3.1 Optional Filter Packages

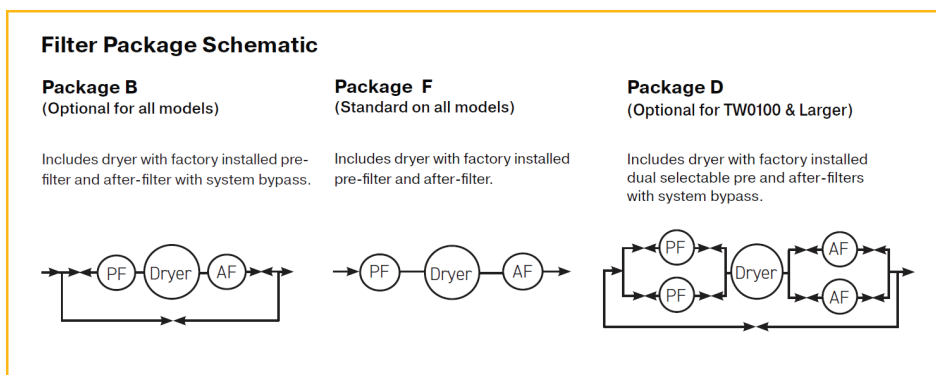

#### 3.2 Stages of Purification

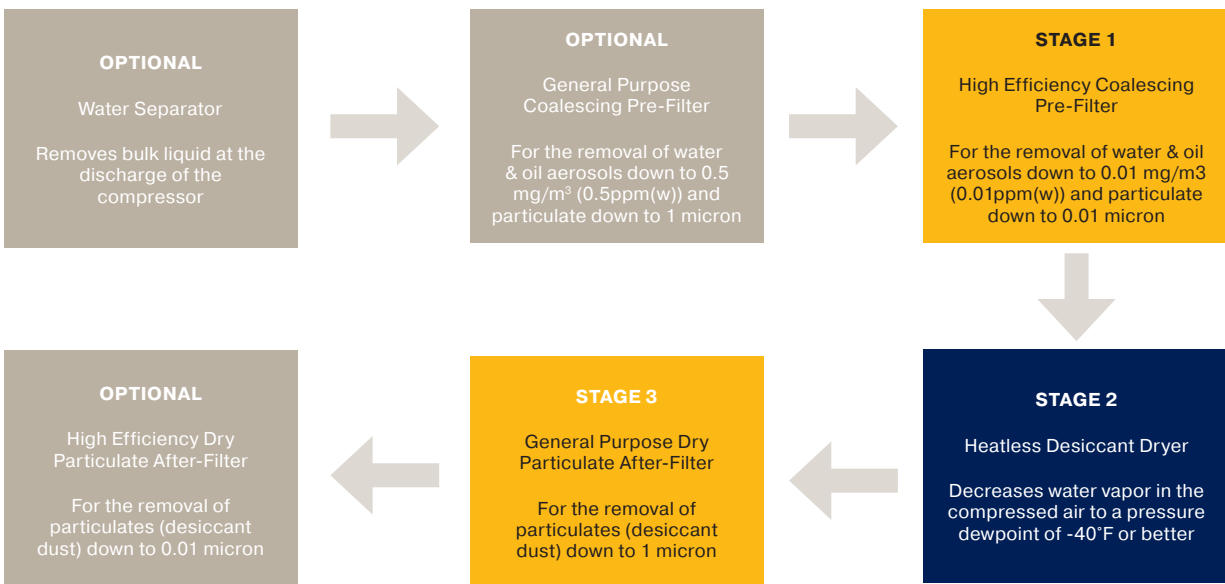

### 3.3 How to Order

Series	Flow Rate (SCFM)	Filter Packages		Controller Type		Power Supply		Electrical Class		Amb. Temp. Package		Drain Option	
		N	No Filters	B	Basic PLC	1	120/1/60	1	NEMA 12	N	40F Ambient Design	N	No Drain
TW	0100	F	Pre & After Filter	P	Basic Plus PLC			X	NEMA 4X SS	L	-20F Ambient Design	F	Float Drain
	0130	B	3 Valve Bypass	A	Advanced PLC			7	NEMA 7 CLASS 1 DIV 2 GROUPS C&D			T	Timed Solenoid Drain
	0200	D	Dual Filters & 9 Valve Bypass	<b>Example: TW0200-FP1XNF</b>									

**NOTES:**

1. Package D filters on Model TW0055 are quote only.
2. Advanced PLC on Model TW0055 is quote only.
3. No drain option only available on Package N Filters (No Filters)
4. Optional high-pressure packages are available for 200 & 250 psig

### 3.4 Technical Specifications

Model	Flow Range @ 100psi g (7 bar g)	Pressure Dewpoint		Pressure Relief Valve Setpoint		Max. Operating Pressure		Min. Operating Pressure		Max. Inlet Temp.		Min. Inlet Temp.		Power Supply	Dryer FLA
	SCFM	°F	°C	psi g	bar g	psi g	bar g	psi g	bar g	°F	°C	°F	°C		
TW0055-TW1500	55 - 1500	-40	-40	165	11.4	150	10.3	80	5.5	120	49	50	10	120v 1Ph 60Hz	2
TW2000 - TW3000	2000 - 3000	-40	-40	150	10.3	135	9.3								

**NOTES:**

1. Above information should be used as a guideline. Flows are at 100 psig inlet pressure, 100°F (38°C) inlet temperature and 100°F (38°C) ambient temperature. For specific applications, please consult Parker Applications Engineering.
2. Pressure relief valve variance +/- 10%.

### 3.5 Product Selection & Correction Factors

Inlet Temperature Correction Factor								
Maximum Inlet Temperature (C1)	°F	90	95	100	105	110	115	120
	°C	32	35	38	41	43	46	49
	CF	1.17	1.15	1.00	0.87	0.76	0.66	0.58



Inlet Pressure Correction Factor								
Minimum Inlet Pressure (C2)	psi g	80	90	100	110	120	130	140
	bar g	5.5	6.2	6.9	7.6	8.3	9	9.7
	CF	0.83	0.91	1.00	1.09	1.17	1.26	1.29

**To obtain dryer capacity at new conditions, multiply nominal capacity x C1 x C2.**

**Example:** TW1000 @ 105°F inlet & 110 psi g inlet → 1000 X 0.87 X 1.09 = 948 SCFM

### 3.6 Weights & Dimensions

Model	Height		Width		Depth		Weight	
	in	mm	in	mm	in	mm	lb	kg
TW0055	79	2007	24	610	27	686	400	181
TW0100	86	2185	52	1321	36	915	468	212
TW0130	86	2185	52	1321	36	915	496	225
TW0200	86	2185	52	1321	36	915	692	314
TW0250	85	2159	52	1321	36	915	776	352
TW0300	85	2159	52	1321	36	915	796	361
TW0400	88	2235	52	1321	36	915	1626	738
TW0500	88	2235	52	1321	36	915	1735	787
TW0600	89	2261	56	1423	60	1524	1740	789
TW0800	89	2261	56	1423	60	1524	2120	962
TW1000	98	2794	65	1651	61	1550	3676	1167
TW1200	110	2794	65	1651	61	1550	4605	2089
TW1500	117	2972	72	1829	77	1956	4985	2261
TW2000	113	2870	118	2997	59	1499	5206	2361
TW2600	111	2820	138	3505	67	1702	7600	3447
TW3000	111	2820	138	3505	67	1702	8300	3765

#### NOTES:

- Weights & dimensions shown for all TW models are approximate. Parker reserves the right to make changes without notification. Consult Parker for general arrangement drawings.
- Weight includes desiccant (shipped loose Models TW2000 and up).

## 4.0 RECEIVING & INSPECTING THE EQUIPMENT

On delivery of the equipment, check the system for damage. If there are any signs of damage to the system immediately contact Parker Hannifin Corporation or the authorized distributor that the equipment was purchased through.

**The dewpoint sensor (basic+ & advanced controller only) is shipped in a small container attached to the dryer. Take care not to misplace before installing.**

**DO NOT USE THE VESSEL LIFTING LUGS TO LIFT THE DRYER. They are only used to lift an empty vessel and are not designed to hold the weight of the equipment.**



### 4.1 General Mechanical Requirements

It is important to ensure that all piping materials are suitable for the application and be clean and free of contaminants. The diameter of the pipe must be sufficient to allow unrestricted inlet air supply to the equipment and outlet air supply to the application.

All components used within the system must be rated to at least the maximum operating pressure of the equipment. It is recommended that the system be protected with suitably rated pressure relief valves.

It is highly recommended to install bypass valves and piping around the dryer and filters to use during routine dryer maintenance.

### 4.2 Recommended System Layout

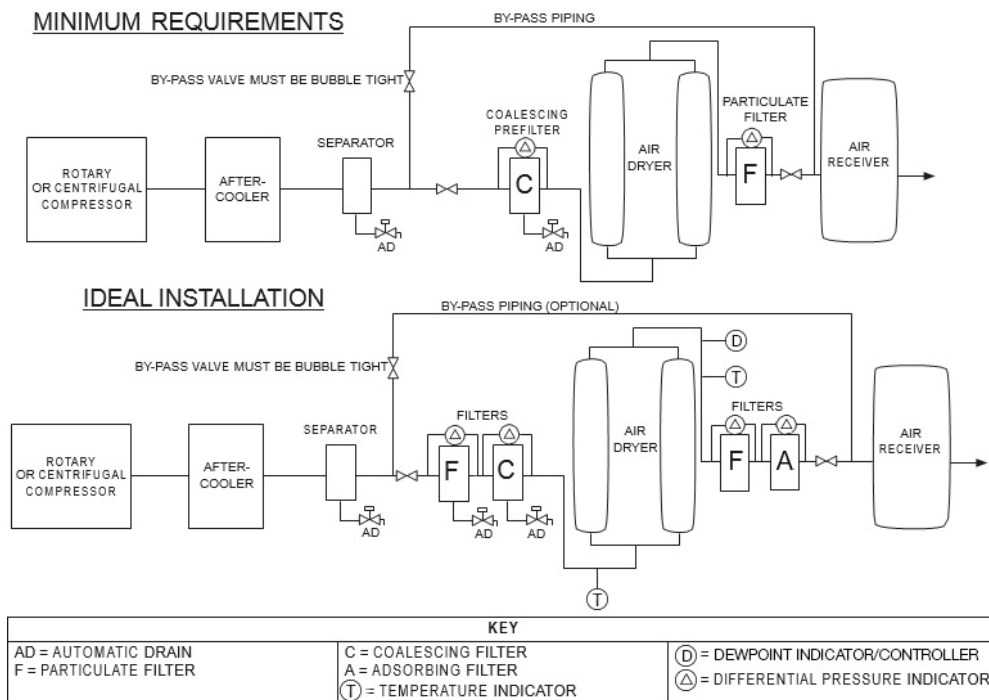



### 4.3 Storage

Upon receiving, if placed in storage, store in a location protected from the environment. If stored outside, it is recommended that the dryer be underneath a shelter and be shrink wrapped or crated to protect against rain. Desiccant dryers should not be stored in a location exposed to freezing temperatures or direct sunlight. Dryers designed for outdoor use should not be placed outside until ready for operation. All plugs and flange covers should remain in place until the dryer is ready to be installed. Desiccant bags should remain in original closed packaging and be stored in a dry environment until dryer is ready for operation. Dryers with desiccant installed should be stored in a dry environment.

### 4.4 Environment

Install in an area with an ambient temperature range of 40°F to 100°F. The area should be well lit and ventilated. It is recommended to leave a minimum of four feet around all sides of the dryer for maintenance. Ensure that the dryer is stable and properly secured on a vibration free floor before operation.

If installed outdoors, the desiccant dryer should be installed in an area protected from the effects of weather. Locate under a roof if possible. Avoid direct sunlight so that the control display does not become damaged and can be clearly read. If installed in an area with below freezing temperatures, proper heat trace and freeze protection must be added to the equipment.

### 4.5 Space Requirements

The equipment should be installed on a flat surface capable of supporting its own weight plus the weight of all ancillary parts. A minimum spacing of approximately 4 feet is recommended around all sides of the unit and above it for maintenance.

### 4.6 Power Supply

Use power cable provided (standard controllers) or bring power to the terminal blocks inside the control panel. Verify voltage and frequency of power supply matches dryer design by checking the serial label.



**WARNING!** Failure to wire the power properly may result in a “HOT” panel which could result in injury or death. Check all power connections before applying power. Use copper supply lines only

### 4.7 Dryer Connections

There are several connection points on the dryer. Make sure each connection is made prior to startup.

- 1. Air in connection** – Will be marked on the dryer with a tag. Use piping suitable for the pressure and temperature class.
- 2. Air out connection** – Will be marked on the dryer with a tag. Use piping suitable for the pressure and temperature class.
- 3. Prefilter drain connection** – Located near the prefilter and labeled. Drain discharge is under pressure equal to the system and must use piping suitable for the pressure and temperature class if piped to another location. A coalescer type prefilter must be installed before the desiccant dryer if not supplied with the dryer. It is critical to the performance of the dryer to protect the desiccant bed from oil bulk moisture contamination.

#### 4.8 Muffler Information

Mufflers are included with the dryer to reduce noise level only. They are not required for normal operation and should not be installed for initial startup. The exhaust may be piped to another location to further reduce noise but must not restrict purge air or dryer performance will suffer.

The following considerations must be taken when piping the exhaust:

**TO 10 FEET, SAME PIPE DIAMETER SIZE AS DRYER EXHAUST VALVE**

**TO 25 FEET, ONE PIPE DIAMETER SIZE LARGER THAN DRYER EXHAUST VALVE TO 50 FEET, TWO PIPE DIAMETER SIZES LARGER THAN DRYER EXHAUST VALVE**

**TO 100 FEET, THREE PIPE DIAMETER SIZES LARGER THAN DRYER EXHAUST VALVE**

Each elbow installed in the exhaust piping is equivalent to 10 feet of pipe. If the exhaust piping is vertical, a drip line must be installed to remove moisture. It is recommended to pipe the exhausts separately for ease of maintenance and troubleshooting.

#### 4.9 Dewpoint Sensor (Basic + & Advanced Only)

On a new dryer, depending on the installation, expect the dryer output to reach  $-40^{\circ}\text{F}$  ( $-40^{\circ}\text{C}$ ) within a few hours of starting up the dryer.

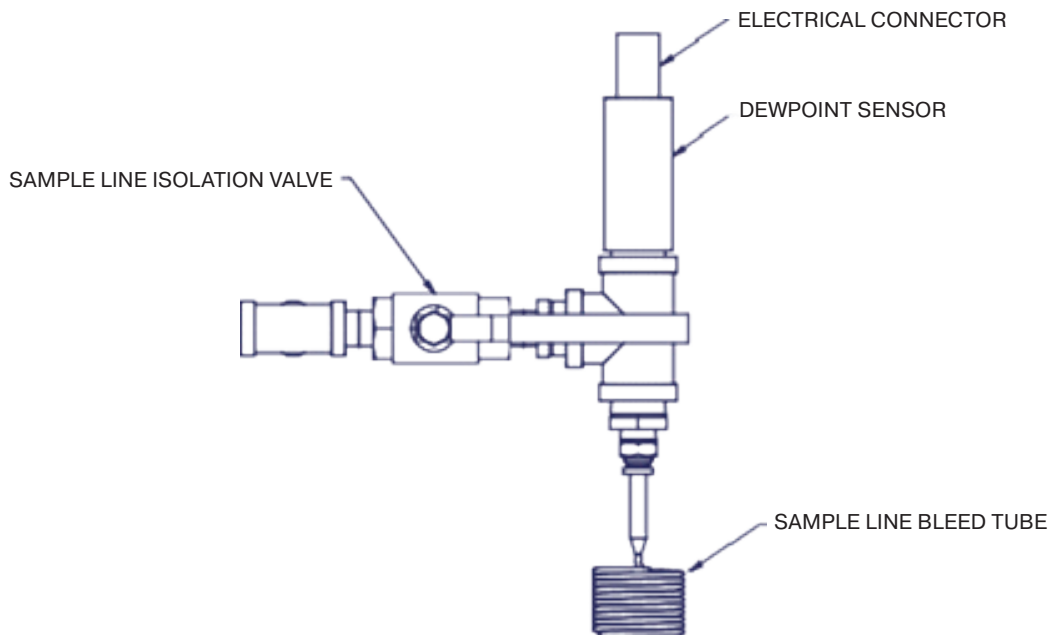

## 5.0 GENERAL OPERATION

The heatless desiccant dryer is designed to remove moisture in water vapor form, from compressed air to yield dewpoints of  $-40^{\circ}\text{F}$  or better. The twin tower design allows constant drying of compressed air through one adsorption vessel while the other vessel desiccant bed regenerates by pressure swing adsorption.

Compressed air is directed through the inlet valve and up through the drying desiccant vessel where moisture is adsorbed by the desiccant. The low dewpoint dry air is then directed through the outlet check valve and downstream for use.

Regeneration of the saturated desiccant vessel bed is begun by blowing down the saturated vessel bed. The quick change from line pressure to atmosphere causes moisture to detach itself from the desiccant and be exhausted.

The regeneration cycle is continued by directing 15% of the dry compressed air through a purge valve and orifice. The purge air is expanded to atmosphere, passed down through the saturated bed removing moisture, and then exits the dryer through the exhaust valve and muffler.

Once regeneration is completed, the offline desiccant vessel is slowly pressurized to line pressure. The dryer is ready for switchover, at which point compressed air will be directed through the newly regenerated desiccant bed for drying and the opposite desiccant vessel begins regeneration. This cycle continues automatically.

The dryer inlet, exhaust, and repressurization valves are controlled by solenoid valves, which are controlled by the dryer PLC. The PLC operates opens and closes the valves by a programmed timing sequence. The PLC is equipped with various timing cycles to maximize the dryer efficiency. It is also possible to operate the dryer on dewpoint demand or compressor demand cycle instead of a timing cycle.

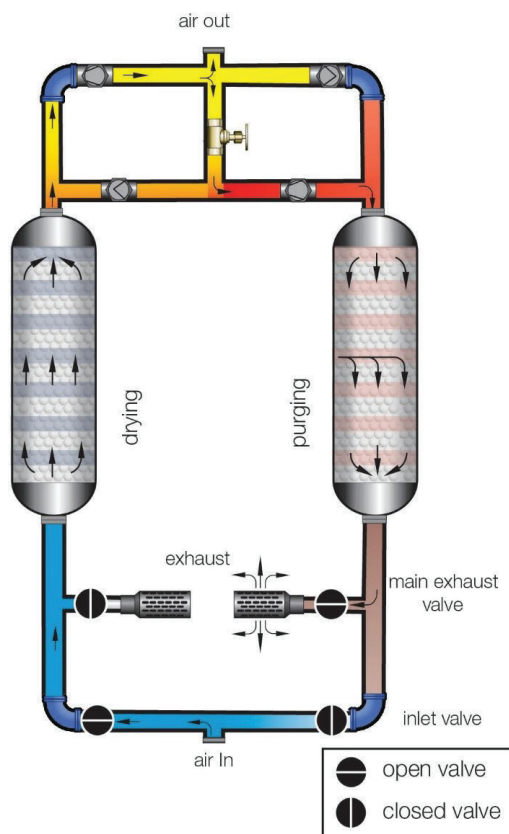

## 6.0 INSTALLATION AND STARTUP

Verify all piping and electrical connections are secure. Do not power the dryer at this time. Start the compressor and pressurize the air system, bypassing the dryer.

Slowly pressurize the dryer by opening the inlet isolation valve. It is important to allow the dryer to slowly pressurize to prevent fluidization of the desiccant bed. Rapid pressurization can also cause damage to the vessel internal screens and filter elements.

Slowly open the dryer outlet isolation valve. Close the bypass valve.

The dryer must be started without the mufflers installed. This will expedite removal of excess desiccant dust and prevent premature clogging of the mufflers.



**CAUTION:** USE EAR AND EYE PROTECTION WHEN OPERATING THE DRYER WITHOUT MUFFLERS. EXCESSIVE NOISE WILL BE CREATED. DUST AND PARTICLES FROM THE SURROUNDING AREA MAY BECOME AIRBORNE. OPERATION WITHOUT MUFFLERS EXCEEDS OSHA LIMITS.

Power up the dryer. Verify timing cycle is set correctly. If you do not want the dryer to begin cycling automatically, close the control air ball valve to keep the inlet and exhaust switching valves in the same position.

Open the control air ball valve. Apply power to the controller to start the dryer. The cycle will begin with blowdown of one of the vessels and drying on the other vessel.

Verify the purge pressure setting is correct for the operating conditions. The purge pressure setting cannot be reduced from the factory setting while using the compressor lock or dewpoint demand features.

After several cycles the mufflers can be installed on the dryer exhaust valves.

## 7. BASIC/ BASIC PLUS CONTROLS MANUAL

### 7.1 Features

- Power 120VAC, 8 ft Cord set **(Except NEMA 7)**
- 4-line alphanumeric display
- Solenoid valves use Lit Din connectors **(EXCEPT NEMA 7)**
- NEMA 12 enclosure standard, NEMA 4X, and NEMA 7 optional
- Dewpoint Sensor, displayed on main screen, High dewpoint alarm **(BASIC PLUS ONLY)**
- Left and right pressure switches – switching failure alarm **(BASIC PLUS ONLY)**
- Run Timer (non-resettable)
- Tank Cycle Counter (non-resettable)
- Tank pressure gauges
- Purge Pressure gauge
- Drain: NEMA 12/4X – Standard - Float (1200 and smaller), Self-Controlled TSD 1500 and Up, Optional, Self-Controlled TSD 1200 and smaller. NEMA 7 – Float Drain Only.
- Filter Timer – Change filter message is displayed when filter timer expires
- Cycle Lock - Dewpoint demand dry contact input
- Compressor-lock dry contact input
- Adjustable Cycle Times 4, 10, 15, 20 minutes
- Optional Enclosure heater for low ambient conditions
- Inlet Valves –Single Acting- Spring to Open, Dual Acting - 1000scfm and higher
- Exhaust Valves –Spring to Close
- Operating temperature range: 32°F to 131°F (0°C to 55°C) , -20F with Low Ambient Package
- Alarms **(BASIC PLUS ONLY)**
  - Dewpoint
  - Blowdown
  - Repressurization
- RED Alarm light on front panel **(BASIC PLUS ONLY)**
- DPDT Alarm relay **(BASIC PLUS ONLY)**

## 7.2 Dryer Information Screen

Upon dryer startup, the display will show the model and version information for 5 seconds. This information can also be accessed from the menu by pressing the OK key from the main display.

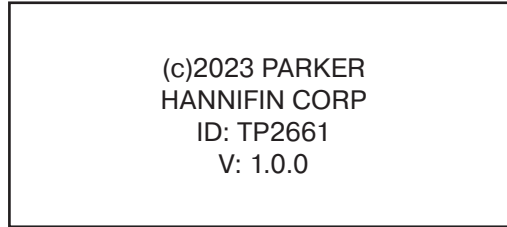

## 7.3 Main Operating Screen (Basic Version)

The default screen for the dryer will display the offline tower and whether it is regenerating (purging) or repressurizing followed by the amount of time left in the current state.

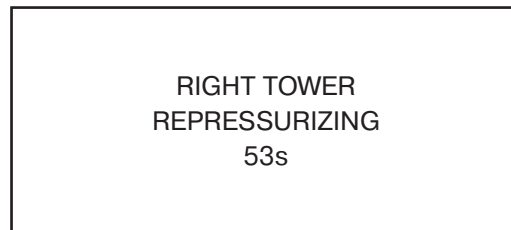

Keys that are active from the main screen

[OK] key will access the menu screens

Right arrow key [>] will step out of regeneration.

[ESC] key will inhibit messages while it is held.

## 7.4 Main Operating Screen (Basic Plus Version)

The default screen for the dryer will display the dewpoint, along with the offline tower and whether it is regenerating (purging) or repressurizing followed by the amount of time left in the current state.

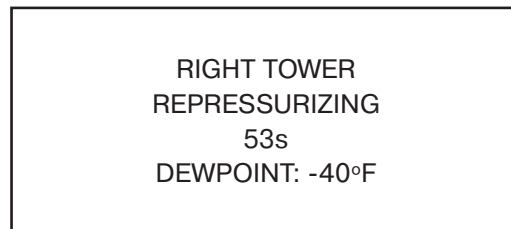
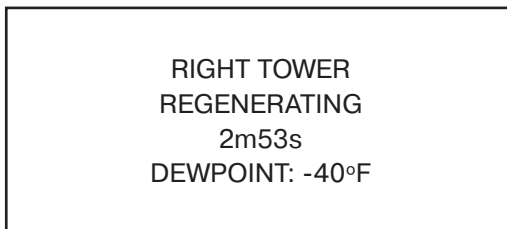

Keys that are active from the main screen

[OK] key will access the menu screens

Right arrow key [>] will step out of regeneration.

[ESC] key will inhibit messages while it is held.

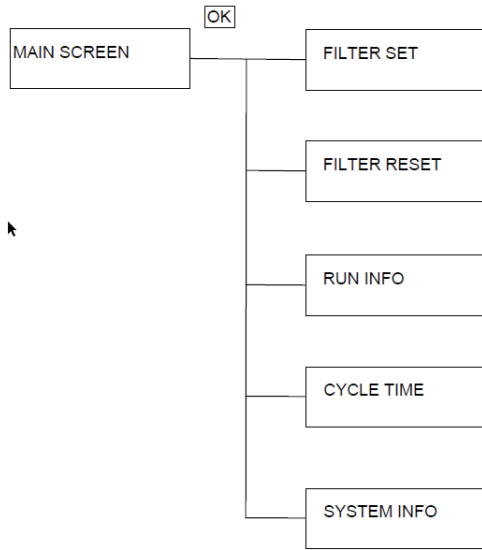

## 7.5 Menu Tree

### BASIC VERSION

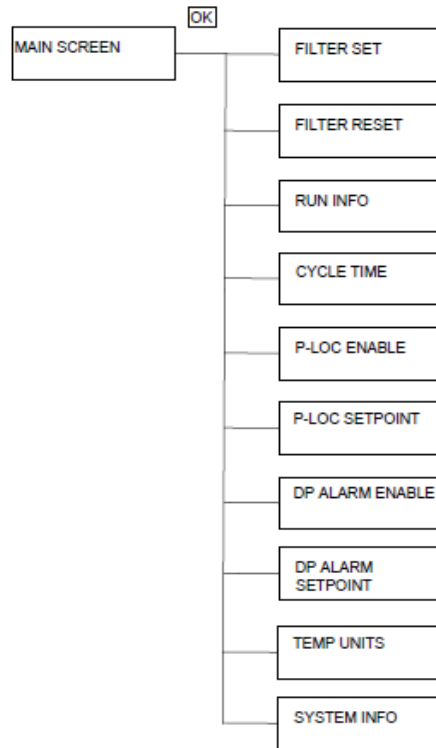

### BASIC PLUS VERSION



	<p>Press to enter the menus and select and store settings.</p>
	<p>Press to go backwards in the menu tree and to abort setting changes.</p>
	<p>Use the arrow keys to scroll thru menus and change settings.</p> <p><b>NOTE:</b> Pressing the right arrow key from the main screen will result in aborting regeneration of the offline tower and proceeding repressurization. (See Manual Stepping section)</p>

### 7.6 Menus (Basic Version)

The menu screens are accessed by pressing the OK key from the main screen.

Use the UP or DOWN arrow keys to cycle thru the menu selection. Press OK to enter a selection. Press ESC to exit to the main display. If no key is pressed for 15 minutes, the display will exit to the main screen.

The Menu allows access to the following:

- Filter Set** - Set the filter timer number of days
- Filter Reset** - Reset the filter timer and show number of days until alarm
- Dryer Run information** – Hour timer and cycle count
- Cycle Time** – Change the cycle timer
- Information** – Controller model and firmware version

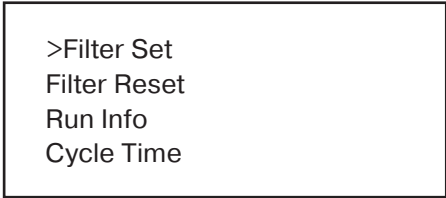

### 7.7 Menus (Basic Plus Version)

The menu screens are accessed by pressing the OK key from the main screen.

Use the UP or DOWN arrow keys to cycle thru the menu selection. Press OK to enter a selection. Press ESC to exit to the main display. If no key is pressed for 15 minutes, the display will exit to the main screen.

The Menu allows access to the following:

- Filter Set** - Set the filter timer number of days
- Filter Reset** - reset the filter timer and show number of days until alarm
- Dryer Run information** – Hour timer and cycle count
- Cycle Time** – Change the cycle timer
- Dewpoint Demand Setting** – Change the dewpoint demand setpoint
- Dewpoint Demand Disable** – Disable the dewpoint demand function
- Dewpoint Alarm Setting** – Change the dewpoint alarm setpoint
- Dewpoint Alarm Disable** – Disable the dewpoint alarm setpoint
- Temperature Units** – Select °F or °C
- Information** – Controller model and firmware version
- Dewpoint Range** – Minimum and maximum dewpoint range
- Dewpoint Trim** – Calibration settings for dewpoint sensor

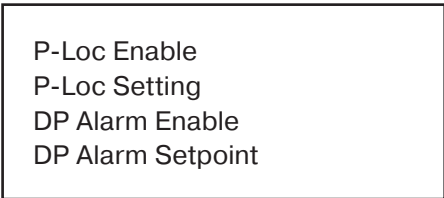
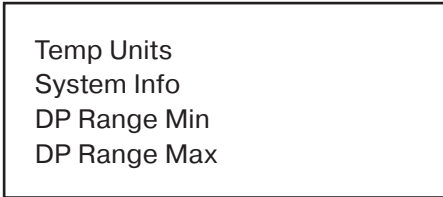
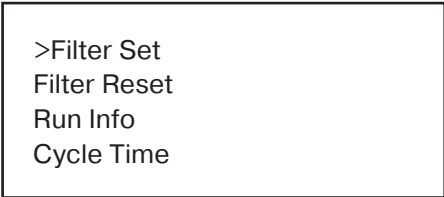



## 7.8 Timing Configuration (100 - 3000 SCFM)

The control panel allows the user to select different timing configurations depending on the air demand flowing through the dryer. The default cycle timing is 10 minutes (5 minutes per side). Selecting 15- or 20-minute cycle timing during periods of light loading reduces the amount of purge air loss, saving energy.

Operating Flow	Cycle Time	Per Tower		
		Drying	Regen	Repress
100%	10 min	5 min	4 min 20 sec	40 sec
75%	15 min	7 min 30 sec	4 min 20 sec	40 sec
50%	20 min	10 min	4 min 20 sec	40 sec
4 min	4 min	2 min	1 min 20 sec	40 sec

The Cycle Time is selected from Cycle Timing setting accessed by the menu screens.

```

CYCLE TIME
10 MIN 100%
[OK] [ESC]

```

Use the DOWN arrow keys to cycle thru the times, then press OK to select. Press ESC to exit without changing the setting.

**NOTE:** For 55 SCFM dryers, the cycle time is not adjustable. It is permanently set to 15 minute cycle (7.5 minutes drying per side), with a repressurization time of 120 seconds.

## 7.9 Compressor Lock Operation

The Compressor Lock feature is an energy savings feature that stops the dryer from using purge air by pausing the regeneration and drying cycle if the systems compressor has stopped running. The cycle lock remote inputs are used to tie the dryer controller to the dry contacts provided by the compressor. While the input is active, the regeneration will immediately pause, and the display will show the following.

```

      WAITING
      FOR
      COMPRESSOR

```

**NOTE:** Only use isolated contacts to provide this signal. Otherwise, damage to the controller may result.

## 7.10 Dewpoint Demand Operation

The Dewpoint Demand feature is an energy savings feature that extends the drying cycle up to 12 hours while the user defined dewpoint requirements are met. The offline desiccant vessel completes its regeneration as normal and waits for the dewpoint to degrade to the analyzer setpoint and then switches over. By extending the cycle, less purge air is consumed.

### 7.10.1 Cycle Lock

A remote input to the controller is available to extend the drying cycle based on the output of a user supplied dewpoint analyzer.

**NOTE:** Only use isolated contacts to provide this signal. Otherwise, damage to the controller may result.

While the dryer is in cycle lock, the following screen will be displayed.

LEFT TOWER  
CYCLE LOCK  
11h33m13s

The dryer will remain in this state for a maximum of 12 hours, after which it will switch towers. Pressing the LEFT arrow key will force the towers to immediately switch.

### 7.10.2 Power Loc - Basic Plus Version Only

A dewpoint probe is used to extend the dryer cycle if the dewpoint is below power loc setting

DEWPOINT DEMAND  
LEFT DRYING  
11h33m13s DEWPOINT: -40°F

The Power loc settings are accessed from the Menu screen by pressing OK from the main screens. The demand can be set from -100 to +20°F. The default is -40°F. The function is enabled by default.

P-LOC ENABLE  
>Enabled  
Disabled  
[OK] [ESC]

P-LOC SET  
Setpoint: -40°F  
[OK] [ESC]

Press and hold UP/DOWN keys to automatically increment setting.



## 7.11 Filter Timer

A programmable filter timer provided a reminder to change the dryer's filters on a regular basis. This filter timer can be set to display a message based on the interval programmed in the filter timer setting.

The following message will be displayed after the filter timer period has expired. In addition, the displays backlight will flash to draw attention to this message.



The timer can be reset from the Filter Reset menu

Press and hold Left arrow key for 3 seconds to silence filter change message for 72 hours

Pressing and holding the escape key will inhibit this message and display the main screen until the escape key is released.

### 7.11.1 Filter Timer Setting

The filter setting menu is accessed from the menus by pressing the OK key from the main display.

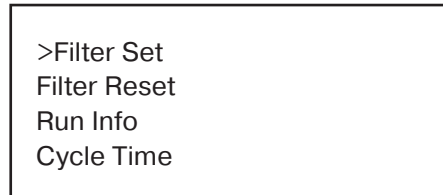

Select Filter Set to set the interval of the timer from 30 to 360 days. The default is 180 days.

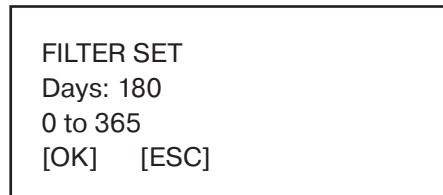

Press and hold UP/DOWN keys to automatically increment setting.

### 7.11.2 Filter Timer Reset

Select Filter Reset to access a screen that displays the number of days remaining until the timer times out. A negative number will be displayed indicating the number of days since the timer has timed out.

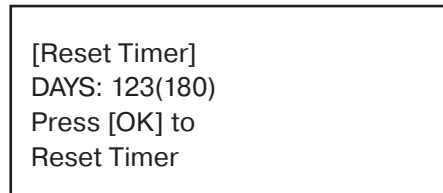

Press the ESC key to exit from this screen without resetting the timer. Press the OK key to reset the timer.

### 7.12 Manual Stepping

This feature is designed to assist in maintenance and troubleshooting of the dryer. Pressing the right arrow key [>] while in the main screen will immediately end the current regeneration stage and step the dryer to repressurization.

Using this feature may yield worse than desired dewpoint until the dryer is allowed to cycle uninterrupted. It is for this reason that this function should only be used for troubleshooting the dryer.

For safety, it is not possible to step out of repressurization.

### 7.13 Run Information Screen

The RUN Information Screen display is accessed by the menu screens by pressing the OK key from the main screen. The display shows the total hours of operation and the total number of cycles since the dryer was first turned on. These values cannot be reset.

```
RUN INFO
001234.5 HOURS
007407 CYCLES
[ESC]
```

### 7.14 Low Pressure Screen (Basic Plus Only)

If both tanks pressure switches open:

- The Repressurization timer will halt

- The low system pressure screen will be displayed.

- The Exhaust Valve will close

- The Repressurization valve will open

- The display will show

```
WAITING FOR
SYSTEM
PRESSURE
DEWPOINT: -40°F
```

### 7.15 Dewpoint Alarm (Basic Plus Only)

If the dewpoint rises above the high dewpoint warning setting for 5 seconds, the High dewpoint screen will display.

```
DEWPOINT
ALARM
```

The dewpoint alarm is reset when the dewpoint falls below the setting for 5 seconds.

Pressing and holding the escape key will inhibit this message and display the main screen until the escape key is released.



### 7.15.1 Dewpoint Settings

The Dewpoint settings are accessed from the Menu screen by pressing OK from the main screens. The dewpoint can be set from -80 to +50°F. The default is -20°F. The alarm is enabled by default.

```

DP ALM ENABLE
>Enabled
Disabled
[OK] [ESC]

```

```

DP ALM SET
Setpoint: -20°F
[OK] [ESC]

```

Press and hold UP/DOWN keys to automatically increment setting.

If the dewpoint input senses a fault, the bottom line on the main display will show “Err” and a dewpoint alarm will occur.

```

RIGHT TOWER
REPRESSURIZING
53s
DEWPOINT: Err

```

### 7.16 Temperature Units (Basic Plus Only)

The Temperature Units setting is accessed from the Menu screen by pressing OK from the main screens.

```

TEMP UNITS
>Fahrenheit
Celsius
[OK] [ESC]

```

### 7.17 Bad Blowdown Alarm (Basic Plus Only)

Depressurization of the left or right tower (as indicated) is incomplete resulting in inefficient regeneration. The alarm occurs if the pressure switch for the regenerating side does not open before the end of regeneration.

```

LEFT TOWER
BAD BLOWDOWN

```

This alarm is automatically reset after both towers regenerate 3 times without an error.

All alarms can be manually reset by pressing and holding the Left arrow key for 3 seconds

Pressing and holding the escape key will inhibit this message and display the main screen until the escape key is released.

### 7.18 Bad Repressurization Alarm (Basic Plus Only)

Left or right tower (as indicated) failed to pressurize to line pressure within the repressurization time. The alarm occurs if the pressure switch for the repressurizing side does not close before the end of repressurization.

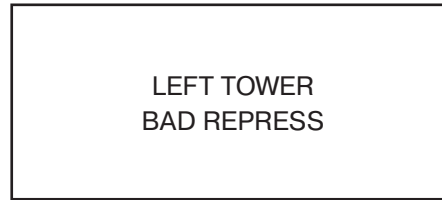

This alarm is automatically reset if both towers regenerate 3 times without an error.

All alarms can be manually reset by pressing and holding the Left arrow key for 3 seconds.

Pressing and holding the escape key will inhibit this message and display the main screen until the escape key is released.

**NOTE:** The towers will not switch until both tower pressure switches are closed for a minimum of 5 seconds.

### 7.19 Alarm Light (Basic Plus Only)

There is a RED light on the front panel which will turn on in the event of an alarm condition.

### 7.20 Alarm Relay (Basic Plus Only)

There is a DPDT relay that can be used to sense an alarm remotely. This relay is active whenever the ALARM light is active.

### 7.21 Remote Reset Input

Alarms and messages can be remotely reset using the remote reset input on the controller. This is useful for situations where it is not practical to access the controller by opening the enclosure. Refer to the wiring diagram for more information.

Pressing and holding the remote reset input will inhibit alarm messages and display the main screen until the input is released.

**NOTE:** Only use isolated contacts to provide this signal. Otherwise, damage to the controller may result.

### 7.22 Loss of Power

If power is disrupted, the following will happen

For dryers sized 1000 and above, the inlet valves have dual acting actuators and therefore will maintain their positions

For dryers sized below 1000 scfm, the inlet valves have spring to open actuators and will immediately open. If there is pressure on the input, then this will result in a surge in tank pressure on the regenerating tank.

The regeneration state will be retained and will resume once power is restored. Once power is restored, the controller will wait until both towers are pressurized before completing regeneration .

It is recommended that the pressure be removed from the dryer or that the dryer be in the fully pressurized state when removing power to the dryer.

### **7.23 Low System Pressure**

The dryer will regenerate if both tower pressure switches indicate low pressure. Regeneration will continue when the towers pressure switch indicate pressure in the online tower.

- **"WAITING FOR SYSTEM PRESSURE"** message will occur
- Both exhaust valves will close
- Repressurization valve will close

## 8.0 ADVANCED CONTROLLER

### 8.1 Features

- Power 120VAC, 8 ft Cord set (NEMA12 only)
- LCD Touch Panel Display
- Modbus TCP communications – standard
- Modbus RTU RS485 communications – option
- IoT Gateway (Except NEMA 7)
- Solenoid valves use Lit Din connectors (Except NEMA 7)
- NEMA 12 enclosure standard, NEMA 4X, and NEMA 7 optional
- Sensors
  - Dewpoint Sensor
  - Inlet pressure and temperature sensors
  - Outlet sensor
  - Left and Right tank pressure sensors
  - Calculated Inlet and outlet filter pressures
- Run Timer (non-resettable)
- Tank Cycle Timer (non-resettable)
- Tank pressure gauges
- Purge Pressure gauge
- Drain - PLC controlled TSD (All models)
- Maintenance Timer
- Optional Drain switch input
- Dewpoint demand contact input
- Compressor sync input
- Adjustable Cycle Times 4, 10, 15, 20 minutes
- Optional Enclosure heater for low ambient conditions
- Inlet Valves – Single Acting- Spring to Open, Dual Acting - 1000scfm and higher
- Exhaust Valves –Spring to Close
- Standard Operating temperature range: 32°F to 140°F (0 to 60°C), -20°F with Low Ambient Package
- Programmable SPST Alarm Relay
- Alarms
  - Failure to switch alarm
  - High Inlet temp alarm
  - High Pdp
  - Low inlet pressure
  - Maintenance timer alarm
  - Blowdown alarm
  - Repress alarm
  - Pre-Filter DP
  - After-Filter DP
  - Muffler alarm





### 8.2 Information Screen

Upon dryer startup, the model and version information screen will show for 5 seconds. This information can also be accessed by touching the service icon  from the main screen and selecting SYSTEM INFORMATION.

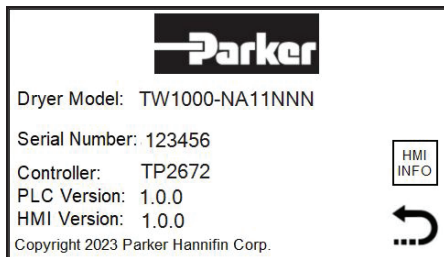

### 8.3 Run Information Screen

The RUN INFORMATION screen is accessed by touching the service icon  from the main screen, then selecting RUN INFORMATION from the list of options.



Displays hours of operation, hours in power save state, and total number of drying cycles since the dryer was first turned on.

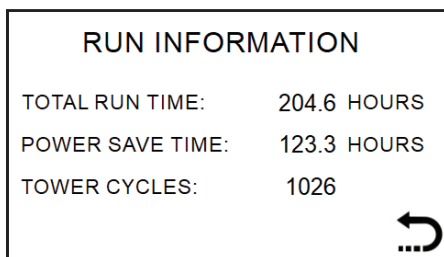



These values cannot be reset or otherwise changed.



## 9. OPERATION

### 9.1 Main Operating Screen

<b>DEWPOINT:</b> -36°F			
<b>REGENERATE LEFT:</b> 00:04:15			
<b>INLET:</b> 80°F	100psi	<b>P-FILTER</b>	
<b>OUTLET:</b>	100psi	0 psid	
<b>L-TOWER</b>	<b>R-TOWER</b>	<b>A-FILTER</b>	
68 psi	100 psi	0 psid	

-  Access Service-Related Functions and information
-  Access active alarms, Alarm History, Reset Alarm
-  Access Trends and Data logging
-  Access settings



### 9.1.1 Status Information

DEWPOINT: -36°F
-----------------

Displays the Dewpoint  
Cycles thru any active alarms (see alarm section for list of alarms).

### 9.1.2 State Information

REGENERATE LEFT: 00:04:15
---------------------------

**Displays state and time left until the end of the state**

**REGENERATE** – Time left in regeneration for indicated tower

**REPRESSURIZE** - Time left in repressurization for indicated tower

**EXTENDED DRYING** – Dewpoint demand – time left until towers switch

**STANDBY** – External RUN/STANDBY signal has paused switching towers

**COMPRESSOR** – External signal from compressor has paused regeneration

**WAITING FOR SYSTEM PRESSURE** – System pressure is less than 60 psi

**UNSAFE TO SWITCH** – Tower pressure is too low to safely open inlet valve

### 9.1.3 Inlet and Outlet Conditions

INLET: 80°F	100psi
OUTLET:	100psi

Displays the Inlet pressure and temperature, as well as the outlet pressure.

The Inlet pressure and temperature are an indicator of how much load there is on the inlet to the dryer.

The Outlet is an indicator of how much pressure drop is across the dryer, including the filters.

### 9.1.4 Tower Pressures

L-TOWER	R-TOWER
68 psi	100 psi

When the dryer is online, the pressure in the drying tower will be at or slightly below the system pressure. A pressure that is 8 psi below the inlet pressure indicates that the inlet filter requires replacement. A pressure that is 8psi above the outlet pressure indicates the outlet filter requires replacement.

When the tower is regenerating, the pressure in the regenerating tower should be at or slightly above zero. A pressure above 5 psi indicates that the exhaust mufflers need replacement.







### 9.1.5 Filter Pressures

<b>P-FILTER</b>	0 psid
<b>A-FILTER</b>	0 psid





Displays the pressure drop across the Pre-Filter and the After-Filter  
 When these pressures are above 8psi, it indicates the filter needs replacement.

### 9.1.6 Screen Background Color

The screen background color will be RED if there is an active unsilenced alarm.

<b>HIGH AFTER-FILTER PRESSURE</b>			
<b>EXTENDED DRYING LEFT:</b> 10:27:15			
<b>INLET:</b> 80°F	100 <sub>psi</sub>	<b>P-FILTER</b>	
<b>OUTLET:</b>	91 <sub>psi</sub>	0 psid	
<b>L-TOWER</b>	100 <sub>psi</sub>	<b>A-FILTER</b>	
<b>R-TOWER</b>	100 <sub>psi</sub>	9 psid	

The screen background will be green if the dryer is in dewpoint demand (DDS) state

<b>DEWPOINT:</b> -45°F			
<b>EXTENDED DRYING LEFT:</b> 10:37:26			
<b>INLET:</b> 80°F	100 <sub>psi</sub>	<b>P-FILTER</b>	
<b>OUTLET:</b>	100 <sub>psi</sub>	0 psid	
<b>L-TOWER</b>	100 <sub>psi</sub>	<b>A-FILTER</b>	
<b>R-TOWER</b>	100 <sub>psi</sub>	0 psid	

## 10. SETTINGS

### 10.1 Settings Menu Tree

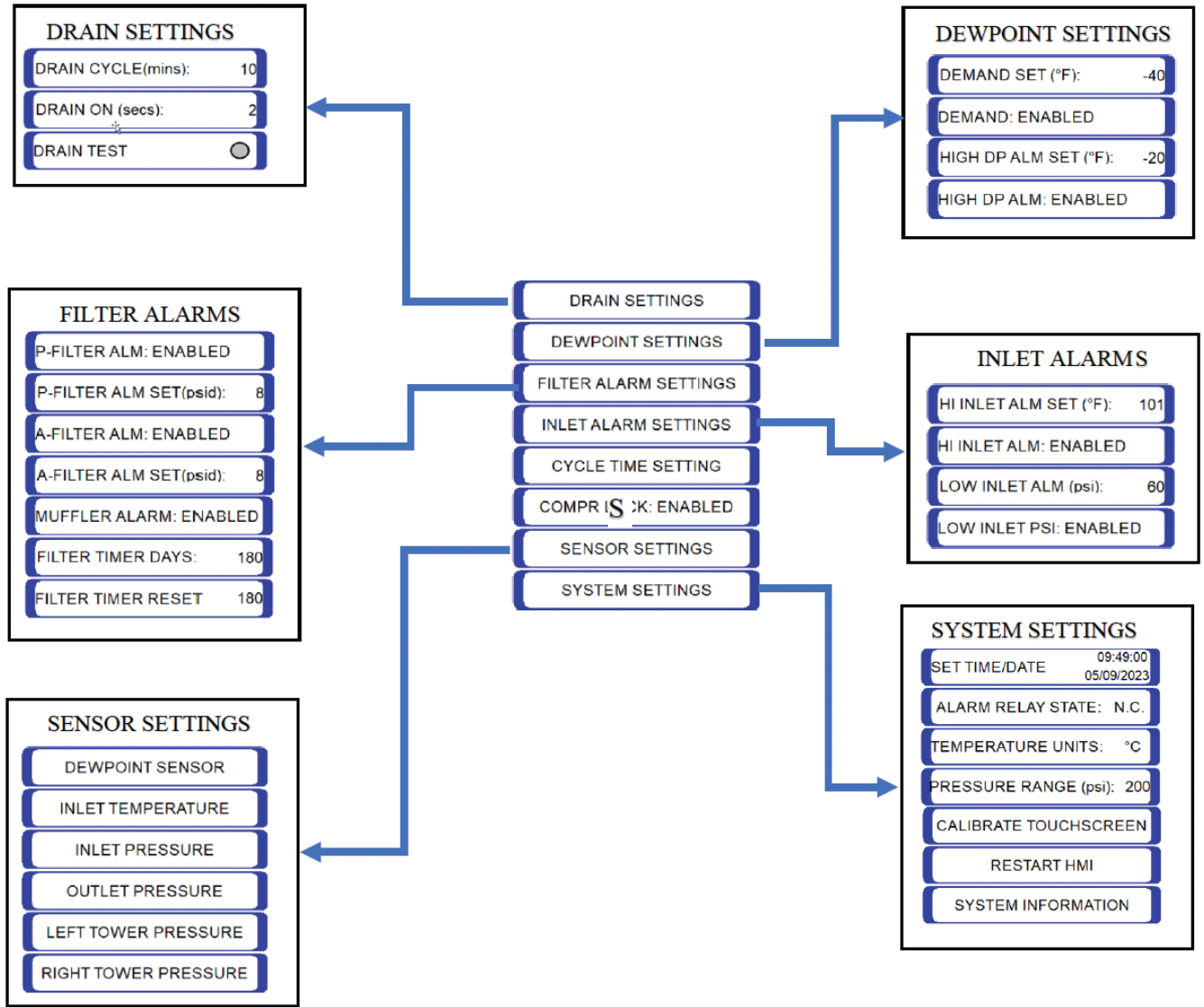

## 10.2 Dewpoint Operation

There is a dewpoint probe shipped with the dryer.

**Demand function:** The Dewpoint Demand (DDS) feature is an energy savings feature that extends the drying cycle up to 12 hours while the user defined dewpoint requirements are met. The offline desiccant vessel completes its regeneration as normal and waits in STANDBY for the dewpoint to degrade to the analyzer setpoint and then switches over. By extending the cycle, less purge air is consumed.

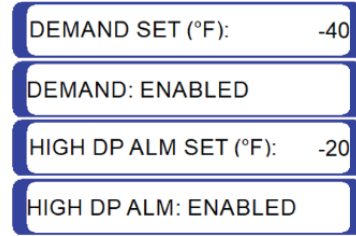

The dryer will remain in this state for a maximum of 12 hours, after which it will switch towers. The demand state can be aborted from the SERVICE screen.

**High Dewpoint Alarm function:** The alarm can be set so that if the dewpoint rises above the setpoint, or the dewpoint probe faults, the dewpoint alarm message appears, and the alarm relay becomes active.

While the dryer is in standby, the main display will show a GREEN background.

If the dewpoint alarm occurs, the main display will show a RED background.

The dewpoint probe related settings are accessed by touching the SETTINGS icon on the main screen, then selecting the DEWPOINT MENU and touching enter.

The demand can be set from -100°F to +20°F. The default is -40°F. The function is enabled by default.

The alarm setting can be set from -80 °F to +50°F. The default is -20°F. The function is enabled by default.

The dewpoint probe, demand function, and alarm functions can be individually disabled.

## 10.3 Drains

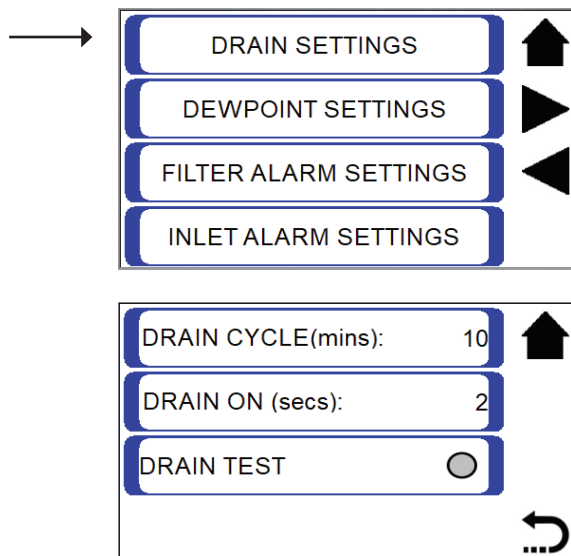

There is a drain timer that opens the drains on a periodic basis. For dryers with multiple drains, all drains are controlled by the same output.

**Drain Cycle** – Set the drain cycle time from 1 to 60 minutes. Default is 10 minutes

**Drain On** – Set the drain on time from 1 to 10 seconds. Default is 5 seconds

**Drain Test** – Touch to open the drain immediately to test the drain function. The drains can also be tested from by touching the service  icon from the main screen and touching DRAINS TEST from the list of options.

**Optional drain float switch.** There is an input on the controller for connecting a drain float switch for sensing when the drain gets plugged. If the drain switch closes, the drain will fire for the Drain On time. If the float switch is open for 5 seconds longer than the drain on time, the drain outputs will pulse 2 seconds open, 2 seconds closed for 10 minutes in an attempt to clear any drain obstructions.

### 10.4 Manual Stepping

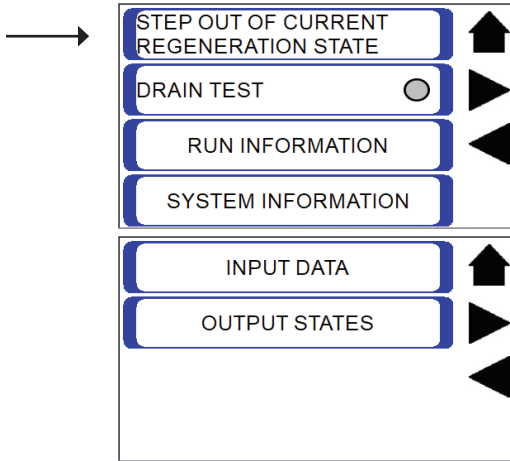

This feature is designed to assist in troubleshooting the dryer by immediately ending the current regeneration stage and stepping the dryer to repressurization.

Over-using this feature may temporarily reduce the performance of the dryer. This function should only be used for troubleshooting the dryer.

To access this function, touch the service icon on the main screen, then select STEP OUT OF CURRENT REGENERATION STATE

For safety, it is not possible to step out of repressurization.

### 10.5 Input/Output Data

For troubleshooting, the input sensor and output relay information is available

To access this information, touch the service icon on the main screen, then select INPUT DATA or OUTPUT DATA.

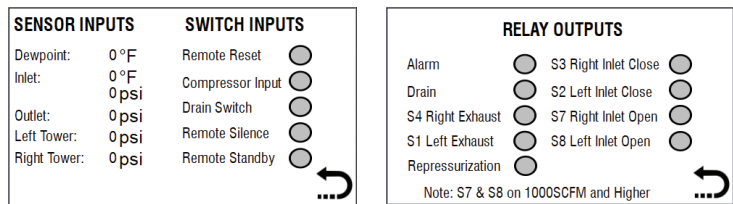

### 10.6 Inlet Pressure and Temperature Monitoring

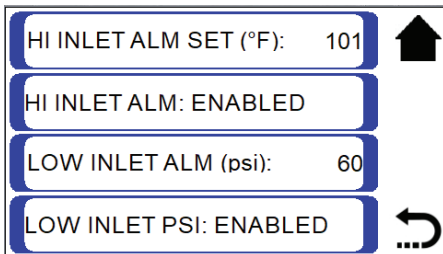

High Inlet Temperature Alarm Setpoint – An alarm will occur if the inlet temperature rises above this setting – refer to alarm section for details.

High Inlet Alarm Enable – This setting allows the High Inlet Temperature Alarm to be disabled.

Low Inlet Pressure Alarm Setpoint – An alarm will sound when the pressure drops below this setting – refer to alarm section for details.

Low Inlet Alarm Enable – This setting allows the Low Inlet Pressure Alarm to be disabled.

### 10.7 Compressor Lock Operation

The Compressor Lock feature is an energy savings feature that stops the dryer from using purge air by pausing the regeneration and drying cycle while the air systems compressor is not running. The cycle lock remote inputs are used to tie the dryer controller to dry contacts provided by the compressor. While the input is active (contacts are closed), the regeneration will immediately pause and wait until the input is released before continuing with regeneration.

To enable and disable the COMPRESSOR LOCK function, touch the settings icon  on the main screen and select the COMPR LOCK selection.

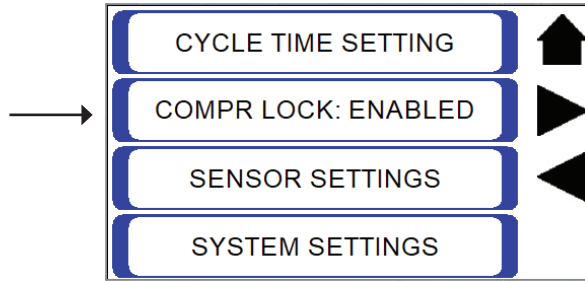

**NOTE:** Only use isolated contacts to provide this signal. Otherwise, damage to the controller may result.

### 10.8 Run/Standby Operations

The dryer can be placed in standby by wiring the run/standby input to a dry contact switch or relay. When the contacts are closed the dryer will pause the current regeneration cycle.

**NOTE:** Only use isolated contacts to provide this signal. Otherwise, damage to the controller may result.

### 10.9 Timing Configuration

The control panel allows the user to select different timing configurations depending on the air demand flowing through the dryer. The default cycle timing is 10 minutes (5 minutes per side). Selecting 15 or 20-minute cycle timing during periods of light loading reduces the amount of purge air loss, saving energy. Selecting shorter cycle times may result in lower dewpoints at the expense of maximum dryer flow. There are also additional selections for non-standard dryer operation

To access the CYCLE TIME SETTING, touch the settings icon  on the main screen and touch the CYCLE TIME SETTING selection.

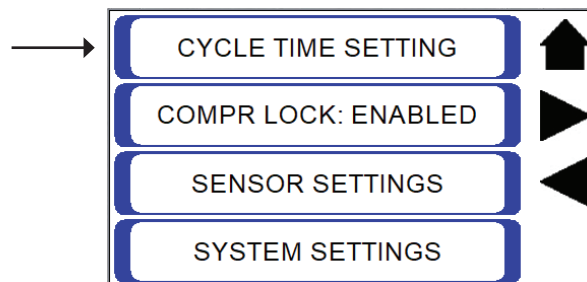

The Cycle Time is selected from Cycle Timing setting accessed by the menu screens.

Use the UP and DOWN arrow keys to cycle thru the selections.

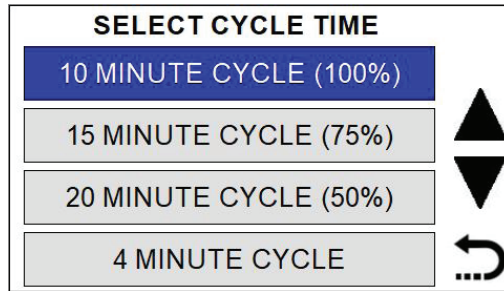

Setting	Cycle Time	Per Tower		
		Drying	Regen	Repress
100% Flow	10 min	5 min	4 min 20 sec	40 sec
75% Flow	15 min	7 min 30 sec	4 min 20 sec	40 sec
50% Flow	20 min	10 min	4 min 20 sec	40 sec
Special	4 min	2 min	1 min 20 sec	40 sec

## 11. FILTERS

A programmable filter timer provides a reminder to change the dryer’s filters on a regular basis. In addition, the inlet filters and outlet filters, as well as the tank mufflers are individually monitored for excessive pressure drop. The display will show RED if the drop across the filters is higher than 8 psi (adjustable), or the back pressure on the exhaust mufflers is higher than 5psi.

The filter alarm settings can be accessed by touching the service icon  from the main screen and selecting FILTER ALARM SETTINGS from the list of selections.

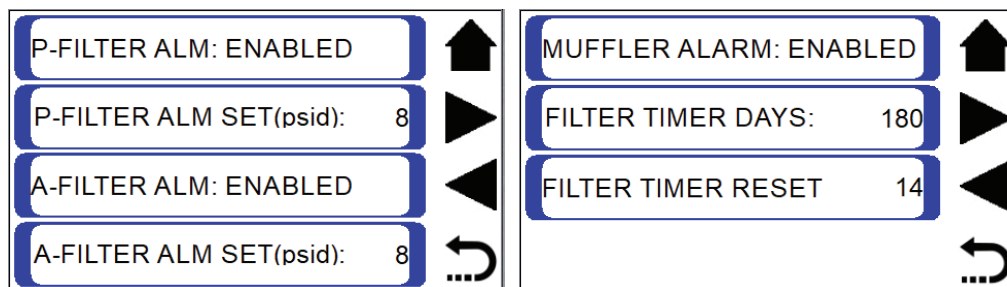



### 11.1 Filter Timer

**Touch FILTER TIMER DAYS:** setting to set the filter timeout from 30 to 360 days. The default is 180 days.

Touch FILTER TIMER RESET to reset the filter timer.

**Filter time remaining:** The filter time remaining value is displayed next to the FILTER TIMER RESET. This will count down from the FILTER TIMER DAYS setting until it reaches zero after which the change filter message will appear. The counter will continue display a negative number indicating how many days have passed since the timeout

Remote Reset Input – Closing the remote reset input after the filter timer reaches zero will result in the filter timer being reset.

### 12. Loss of Power

If power is disrupted, the following will happen

- For dryers sized 1000 - 3000 SCFM, the inlet valves have dual acting actuators and therefore will maintain their positions
- For dryers sized below 100 - 800 SCFM, the inlet valves have spring to open actuators and will immediately open. If there is pressure on the inlet, then this will result in a surge in tank pressure on the regenerating tank.
- The regeneration state will be retained and will resume once power is restored. Once power is restored, the controller will wait until both towers are pressurized before completing regeneration.

It is recommended that both towers be the same pressure when removing power to the dryer.

### 13. Low System Pressure

The dryer will not regenerate if the inlet pressure is less than 50psi and will wait until the pressure rises above 60 psi before switching the inlet valves.

- "LOW SYSTEM PRESSURE" will show on the status line on the main display
- "WAITING FOR SYSTEM PRESSURE" will show on the operating state line on the main display
- Both exhaust valves will close
- The Repressurization valve will close

## 14. SENSOR RANGE AND OFFSET SETTINGS

The sensors can be adjusted by touching the service icon from the main screen and selecting SENSOR SETTINGS from the list of selections.

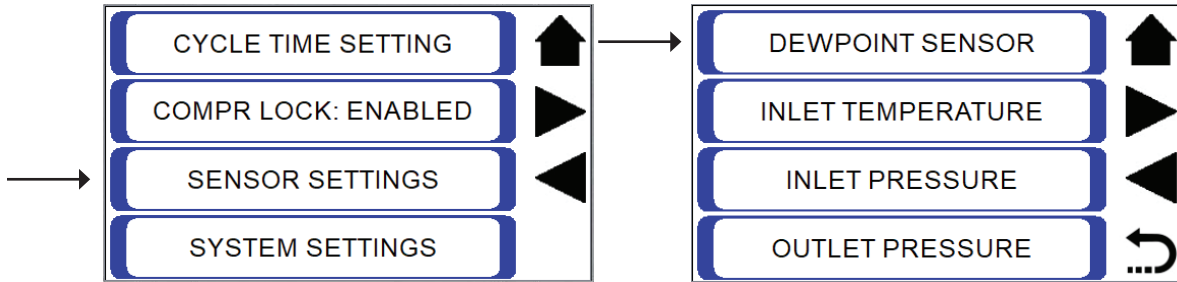

### 14.1 Dewpoint Sensor

The dewpoint probe settings are

**PROBE:** ENABLED OR DISABLED – use to disable the probe during maintenance

**OFFSET ADJUST:** Use to adjust the probe value

**MINIMUM:** Use to set the minimum sensor range for non-standard probes

**MAXIMUM:** Use to set the maximum sensor range for non-standard probes

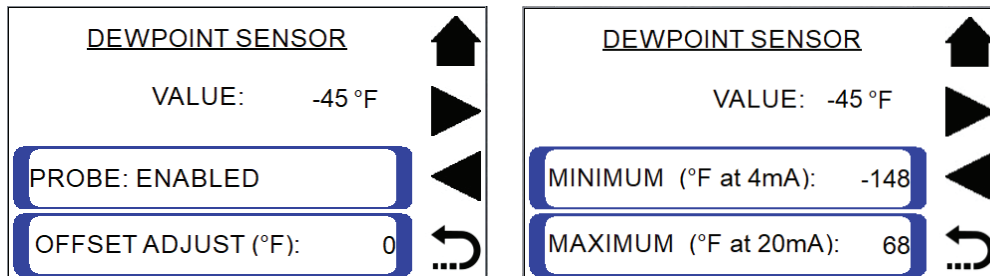

### 14.2 Pressure Sensor Offset

The pressure offset adjustment can be used to correct for minor offsets in the sensor reading. Remove air from the system until the pressure is zero, then change the offset setting until the value shows 0. Do this for the INLET, OUTLET, LEFT and RIGHT sensors.

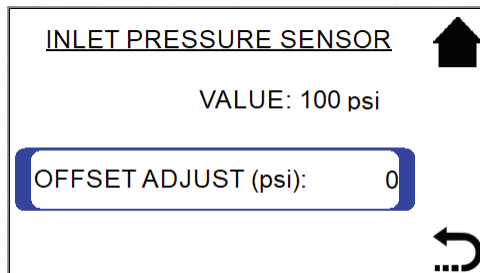

### 14.3 Inlet Temperature Offset

The temperature offset adjustment can be used to correct for minor offsets in the inlet temperature probe. Remove the temperature probe from the inlet air temperature port and wait for the value to settle. Compare the value to a known thermometer and adjust the offset until they agree.

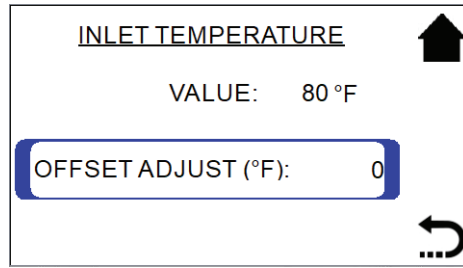

### 15. SYSTEM SETTINGS

To access the system settings, touch the settings icon  from the main screen. Use the UP/DOWN keys to select the SYSTEM SETTINGS

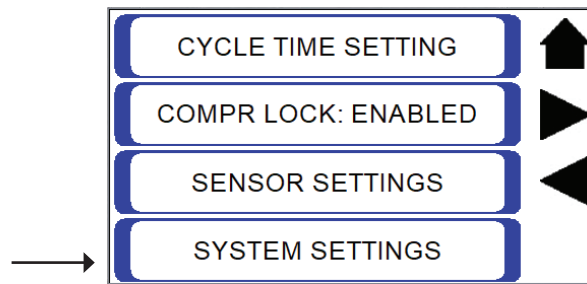

The system settings menu will appear. Use the arrow keys to select the desired setting

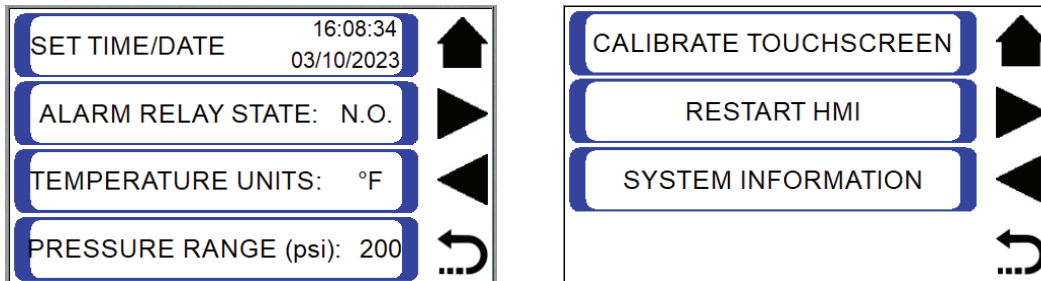

- SET TIME DATE SETTING: Set the system time and date. Required for accurate alarm and logging data.
- ALARM RELAY STATE: Toggle between normally open and normally close alarm relay operation
- TEMPERATURE UNITS: Toggle between F and C temperature units
- PRESSURE RANGE: Change the range of the pressure sensors. This is required for high pressure systems
- CALIBRATE TOUCHSCREEN: Adjust the touchscreen if it appears that it is not sensing finger touches accurately.
- RESTART HMI: Reboot the HMI.
- SYSTEM INFORMATION: Display dryer model and serial number, and firmware model and revision

## 16. ALARMS

### 16.1 Alarm Table

Alarm	Description
W1: HIGH DEWPOINT	Alarm occurs whenever the dewpoint rises above the user adjustable setpoint for 5 seconds.
W2: HIGH INLET TEMPERATURE	Alarm occurs whenever the inlet temperature rises above the user adjustable setpoint for 2 seconds. Alarm resets once the inlet temperature falls below the setpoint for 2 seconds or can be manually reset by the operator. Default = 101°F (38 °C), adjustable from 50°F (10 °C) to 150°F (66°C) This alarm can be disabled from the settings menu.
W3: LOW INLET PRESSURE	Alarm occurs if the inlet pressure falls below the user adjustable setpoint for 5 minutes. Alarm resets once pressure rises above the setpoint for 2 seconds or can be reset manually by the operator. Default = 60psi (4.1 bar) , adjustable from 20 psi (1.4 bar) to 100 psi (6.9 bar Pa) This alarm can be disabled from the settings menu.
W4: LEFT CLOGGED MUFFLER	Alarm occurs if the tower pressure in the regenerating tower is $\geq$ 5 psi (0.34 bar) at the end of regeneration. Operator must manually reset this alarm. This alarm can be disabled from the settings menu.
W5: RIGHT CLOGGED MUFFLER	
W6: INLET FILTER PRESSURE	Alarm occurs if the inlet or outlet pressure drop across the filter rises above the user adjustable setpoint for 5 minutes. Alarm must be reset manually by the operator. Default = 8psi (0.6 bar) , adjustable from 0 psi (0 kPa) to 15 psi (1.0 bar ) This alarm can be disabled from the settings menu.
W7: OUTLET FILTER PRESSURE	
W8: CHANGE FILTERS	Indicates user settable filter timer has elapsed Default is 180 days, adjustable from 30 to 360 days Manually resetting this alarm will reset the timer
A1: LEFT TOWER FAILED TO BLOWDOWN	Alarm occurs if the tower pressure in the regenerating tower is $\geq$ 10 psi (0.70 bar) for 60 seconds after the exhaust opens. Operator must manually reset this alarm. This alarm can be disabled from the settings menu.
A2: RIGHT TOWER FAILED TO BLOWDOWN	
A3: LEFT TOWER FAILED TO PRESSURIZE	Alarm occurs if the difference between the two tower pressures is $>$ 10 psi (0.70 bar) when the dryer is called to switch towers. Operator must manually reset this alarm. This alarm can be disabled from the options menu. The dryer will not switch towers until the pressure is reduced below the threshold
A4: RIGHT TOWER FAILED TO PRESSURIZE	
A5: SWITCHING FAILURE	Alarm occurs whenever the pressure drop across the inlet valve (including the filter) rises above 15 psi (1.0 bar) for 2 seconds Alarm must be manually reset by the operator. No user adjustments The dryer will not switch towers until the pressure is reduced below the threshold
A6: LEFT TOWER PRESSURE SENSOR FAULT	Alarm occurs if the sensor input indicates an open or a shorted sensor. Operator must manually reset this alarm.
A7: RIGHT TOWER PRESSURE SENSOR FAULT	
A8: INLET PRESSURE SENSOR FAULT	
A9: OUTLET PRESSURE SENSOR FAULT	
A10: DEWPOINT SENSOR FAULT	
A11: INLET TEMPERATURE SENSOR FAULT	Alarm occurs if the sensor input indicates an open thermocouple. Operator must manually reset this alarm

**Touch the individual alarm to display a description of the alarm**

**ALARM RELAY INDICATOR:** Displays the current state of the alarm relay

**RESET ALARMS:** Touch to reset all active alarms.

**SILENCE ALARMS:** Touch to reset the alarm relay and main screen background color until the next alarm occurs.

**ALARM HISTORY:** Touch to display the alarm history.

**EXPORT ALARM HISTORY:** Touch to export data and alarm logs.

**CLEAR ALARM HISTORY:** Touch to clear the alarm log.

ALARMS DASHBOARD				
W1 HIGH DEWPOINT	W2 HIGH INLET TEMP	W3 LOW INLET PRESSURE	W4 LEFT MUFFLER	W5 RIGHT MUFFLER
W6 P-FILTER PRESSURE	W7 A-FILTER PRESSURE	W8 CHANGE FILTER	A1 BAD LEFT BLOWDOWN	A2 BAD RIGHT BLOWDOWN
A3 BAD LEFT REPRESS	A4 BAD RIGHT REPRESS	A5 SWITCHING FAILURE	A6 LEFT PRES SENSOR	A7 RIGHT PRES SENSOR
A8 INLET PRES SENSOR	A9 OUT PRES SENSOR	A10 DEWPOINT PROBE	A11 INLET TEMP SENSOR	

ALARM RELAY

1 ALARM HISTORY		
TIME	DATE	MESSAGE
16:13	03/10/23	HIGH AFTER-FILTER P...

**16.2 Dewpoint Alarms**

If the dewpoint rises above the high dewpoint warning setting for 2 seconds, the High dewpoint alarm will be logged, and the alarm relay will be active

HIGH DEWPOINT ALARM will show on the status line of the display

The alarm is reset after the dewpoint value falls below the alarm setting for 2 seconds.

The dewpoint related settings are accessed by touching the SETTINGS icon on the main screen, then selecting the DEWPOINT settings.

The dewpoint alarm can be set from -80 to +50°F. The default is -20°F. The alarm is enabled by default.

The dewpoint alarm function can be disabled from the DEWPOINT setting screen.

W1 - HIGH DEWPOINT ALARM

Alarm occurs whenever the dewpoint rises above the user adjustable setpoint for 2 seconds.

Alarm resets when the dewpoint falls below the setpoint for 2 seconds.

Default is -20 °F(-29 °C), adjustable from -80°F( -62°C) to 10°F(-7 °C)

This alarm can be disabled from the DEWPOINT SETTINGS options.



### 16.3 Bad Blowdown Alarm

The tank pressures are monitored during regeneration to ensure that the tank pressure drops to near zero during regeneration.

If the tank pressure is greater than 10psi at the end of regeneration, “BAD BLOWDOWN – LEFT” (or RIGHT) will be displayed on the status line and the tank color will show yellow.

This alarm is automatically reset after both towers regenerate without an error during regeneration.

A1, A2 - LEFT/RIGHT TOWER FAILED TO BLOWDOWN

Alarm occurs if the tower pressure in the regenerating tower is  $\geq$  10psi (69kPa) for 60 seconds after the exhaust opens.

Operator must manually reset this alarm.



### 16.4 Bad Repressurization Alarm

The tank pressures are monitored during repressurization to ensure that the tank pressures equalize before switching towers.

If the difference between the left and the right tanks is greater than 10 psi at the end of repressurization, “BAD REPRESSURIZATION - LEFT” (or RIGHT) will be displayed on the status line and the tank color will show red.

This alarm is automatically reset if both towers repressurize without an error for 2 consecutive cycles.

**NOTE:** To avoid damaging the desiccant, the towers will not switch until both tower pressures are within 10 psi of each other for 5 seconds.

A3, A4 - LEFT/RIGHT TOWER FAILED TO PRESSURIZE

Alarm occurs if the difference between the two tower pressures is  $>$  10psi (70kPa) when the dryer is called to switch towers.

Operator must manually reset this alarm.

The dryer will not switch towers until the pressure difference is below 10psi (70kPa)



### 16.5 High Muffler Pressure Alarm

If the pressure in the regenerating tower is greater than or equal to 5 psid, then a high muffler pressure alarm will occur. The pressure is checked at the end of regeneration.

**W4, W5 - LEFT/RIGHT MUFFLER CLOGGED**

Alarm occurs if the tower pressure in the regenerating tower is  $\geq$  5psi (34kPa) at the end of regeneration.

Operator must manually reset this alarm.

This alarm can be disabled from the FILTER ALARM SETTINGS options.



### 16.6 Inlet Temperature Alarm

**W2: HIGH INLET TEMPERATURE ALARM**

Alarm occurs whenever the inlet temperature rises above the user adjustable setpoint for 2 seconds.

Alarm resets once the inlet temperature falls below the setpoint for 2 seconds or can be manually reset by the operator.

Default is 101 °F (38 °C)  
Adjustable from 50°F (10 °C) to 150 °F (66 °C)

This alarm can be disabled from the INLET ALARM SETTINGS options.



### 16.7 Inlet Pressure Alarm

**W3 - LOW INLET PRESSURE ALARM**

Alarm occurs if the inlet pressure falls below the user adjustable setpoint for 5 minutes.

Alarm resets once pressure rises above the setpoint for 2 seconds or can be reset manually by the operator.

Default is 60psi (414kPa)  
Adjustable from 20psi(138kPa) to 100psi(689kPa)

This alarm can be disabled from the INLET ALARM SETTINGS options.



## 16.8 Inlet/Outlet Filter Pressure Alarm

**W6, W7 - INLET/OUTLET FILTER PRESSURE ALARM**

Alarm occurs if the inlet pressure drop across the filter rises above the user adjustable setpoint for 5 minutes.

Alarm must be reset manually by the operator.

Default is 8psi (55kPa) , adjustable from 0psi(0kPa) to 15psi(100kPa)

This alarm can be disabled from the FILTER ALARMS SETTINGS options.



**W8:CHANGE FILTERS**

Indicates user settable filter timer has elapsed

Default is 180 days, adjustable from 30 to 360 days

Manually resetting this alarm will reset the timer



## 16.9 Switching Failure Alarm

**A5 - SWITCHING FAILURE ALARM**

Alarm occurs whenever the pressure drop across the inlet valve (including the filter) rises above 15psi (100kPa) for 2 seconds

Alarm must be manually reset by the operator.

No user adjustments

The dryer will not switch towers until the pressure is reduced below the threshold



## 16.10 Sensor Fault

If any of the sensors are outside their normal output ranges, then it is assumed that the sensor, sensor cable, or sensors input circuit is faulty.

DEWPOINT SENSOR ALARM will show in the status line of the display and the dewpoint will show “error”

The alarm is reset after the dewpoint value is valid for 2 seconds.

This fault condition is disabled if the dewpoint probe is disabled from the DEWPOINT MENU screen.

**A6 thru A11 - SENSOR FAULT**

Alarm occurs if the sensor input indicates an open or a shorted sensor.

Operator must manually reset this alarm.





### 16.11 Alarm Relay

There is a SPST relay that can be used to sense an alarm remotely. This relay is active whenever there is an active alarm. The relay contacts can be programmed to be normally open or normally closed from the ALARM RELAY setting in the Systems Settings menu.

Selecting NORMALLY CLOSED will result in an open contact if the dryer is powered down. This is useful for determining if the dryer loses power, since the relay will open if power to the dryer is interrupted.

### 16.12 Remote Reset Input

Alarms and messages can be remotely reset using the remote reset input on the controller. This is useful for situations where it is not practical to access the controller by opening the enclosure. Refer to the wiring diagram for more information.

Closing this input will result in resetting active alarms and will also reset the filter maintenance timer if it is at or below 0 days.

**NOTE:** Only use isolated contacts to provide this signal. Otherwise, damage to the controller may result

## 17. TRENDS AND DATALOGS

The trend screen gives access to trends and data logging.

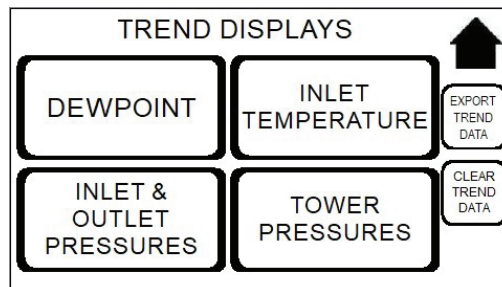

Press the trend that you are interested in.

#### NOTES:

- It can take several seconds for the trend data to load depending on the amount of data being displayed.
- The display will be unresponsive while the trend data is loading.

EXPORT TREND DATA: Touch to export data.

CLEAR TREND DATA: Touch to clear all trend data.

## 17.1 Datalogs Export

To export data to a flash drive, touch the EXPORT TREND DATA key

Insert the flash drive

Once it is detected, select the length of time to download.

You can also select only the alarm log by touching EXPORT ALARM LOG

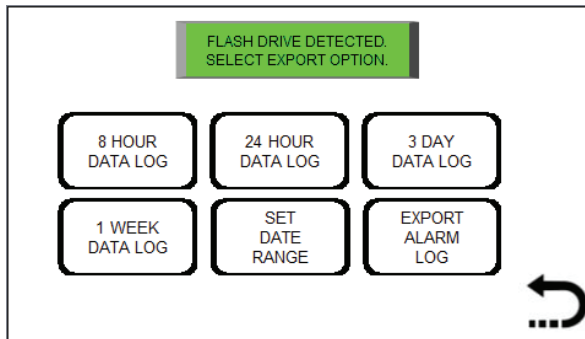

### NOTE:

- It can take several minutes to upload a data log depending on the amount of data that is being requested.
- The display will be unresponsive while the download is taking place.

## 18. Modbus Communications

Ethernet Communications - The dryer comes standard with an Ethernet Modbus TCP/IP interface located along the bottom edge of the PLC. The ethernet port comes preconfigured in DHCP Mode.

To change the static IP address, see the SETTING STATIC IP ADDRESS section.

Note: Once a static IP address has been set, the IP Address Mode can not be changed back to DHCP mode.

Connect the Ethernet cable to the Ethernet port on the bottom of the controller.

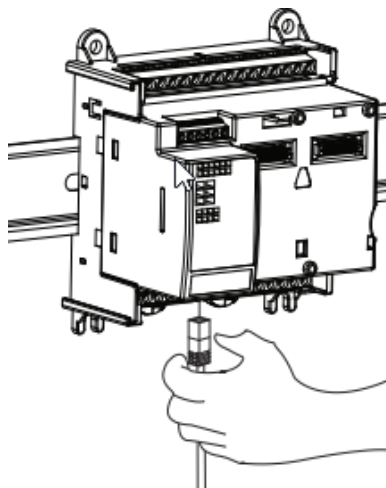

## 18.1 Modbus Map

PLC Modbus Address	R/W	Function	Units	Min	Max	Def.	Notes
00001	W	Alarm Setting - Clear all alarms	state	0	1	-	1 = Clears all alarm bits
00002	W	Control Setting - Test Drains	state	0	1	-	1 = Test drains
00003	R/W	Control Setting - Variable Cycling Time Enable	state	0	1	1	0 = disabled, 1 = enabled
00004	R/W	Control Setting - Compressor Lock Input Enable	state	0	1	1	0 = disabled, 1 = enabled
00005	R/W	Control Setting - Dewpoint Sensor Enable	state	0	1	1	1 = sensor installed
00006	R/W	Alarm Setting - Dewpoint Alarm Enable	state	0	1	1	0 = disabled, 1 = enabled
00007	R/W	Alarm Setting - High Inlet Temp Alarm Enable	state	0	1	1	0 = disabled, 1 = enabled
00008	R/W	Alarm Setting - Low Inlet Pressure Alarm Enable	state	0	1	1	0 = disabled, 1 = enabled
00009	R/W	Alarm Setting - Blowdown Alarm Enable	state	0	1	1	0 = disabled, 1 = enabled
00010	R/W	Alarm Setting - Repressurization Alarm Enable	state	0	1	1	0 = disabled, 1 = enabled
00011	R/W	Alarm Setting - High Muffler Pressure Enable	state	0	1	1	0 = disabled, 1 = enabled
00012	W	Alarm Setting - Reset Filter Days Timer	state	0	1	-	1 = Resets filter days
00013	R/W	Control Setting - Alarm Relay State Control	state	0	1	0	0 = Normally Open, 1 = Normally Closed
00014	W	Setting - Use Celsius	state	-	1	-	1 = C, 0 = F
00015	W	Manually Step to End of Regeneration	state	-	1	-	1 = Step out of regeneration
00016	R/W	Silence Alarm	state	-	1	-	1 = Silence relay and alarm display
00017	R/W	Alarm Setting - Inlet Filter Alarm Enable	state	0	1	1	0 = disabled, 1 = enabled
00018	R/W	Alarm Setting - Outlet Filter Alarm Enable	state	0	1	1	0 = disabled, 1 = enabled
10001	R	Alarm - Left Blowdown	state	0	1	-	1 = Alarm
10002	R	Alarm - Right Blowdown	state	0	1	-	1 = Alarm
10003	R	Alarm - Left Repressurization	state	0	1	-	1 = Alarm
10004	R	Alarm - Right Repressurization	state	0	1	-	1 = Alarm
10005	R	Alarm - High Inlet Temp	state	0	1	-	1 = Alarm
10006	R	Alarm - Low Inlet Pressure	state	0	1	-	1 = Alarm
10007	R	Alarm - High Dewpoint	state	0	1	-	1 = Alarm
10008	R	Alarm - Left Tower Pressure Sensor Fault	state	0	1	-	1 = Alarm

PLC Modbus Address	R/W	Function	Units	Min	Max	Def.	Notes
10009	R	Alarm - Right Tower Pressure Sensor Fault	state	0	1	-	1 = Alarm
10010	R	Alarm - Inlet Pressure Sensor Fault	state	0	1	-	1 = Alarm
10011	R	Alarm - Outlet Pressure Sensor Fault	state	0	1	-	1 = Alarm
10012	R	Alarm - Dewpoint Sensor Fault	state	0	1	-	1 = Alarm
10013	R	Alarm - Inlet Temperature Sensor Fault	state	0	1		1 = Alarm
10014	R	Alarm - Filter Timer	state	0	1	-	1 = Alarm
10015	R	Alarm - Not Used	state	0	1	-	1 = Alarm
10016	R	Alarm - High Left Muffler Pressure	state	0	1	-	1 = Alarm
10017	R	Alarm - High Right Muffler Pressure	state	0	1	-	1 = Alarm
10018	R	Alarm - Inlet Filter Pressure	state	0	1	-	1 = Alarm
10019	R	Alarm - Outlet Filter Pressure	state	0	1	-	1 = Alarm
10020	R	Alarm - Switching Fail	state	0	1	-	1 = Alarm
10021	R	reserved	state	0	1	-	
10022	R	reserved	state	0	1	-	
10023	R	reserved	state	0	1	-	
10024	R	Output - Drain Valve	state	0	1	-	1 = Drain is open
10025	R	Status - Repressurizing	state	0	1	-	1 = Repressurizing Offline Tower
10026	R	Status - Regenerating	state	0	1	-	1 = Regenerating Offline Tower
10027	R	Status - Currently in extended drying	state	0	1	-	1 = variable drying time conditions met
10028	R	Status - Compressor Lock Active	state	0	1	-	1 = Regenerating paused due to compressor lock input
10029	R	Status - Alarm	state	0	1	-	1 = New Alarm Condition has occurred
10030	R	Status - Pressure OK	state	0	1	-	1 = Pressures are OK to switch
10031	R	Status - Remote Control Allowed	state	0	1	-	0 = Remote commands are ignored
10032	R	Status - Remote Standby (Option)	state	0	1	-	1 = Remote Standby input is close
10033	R	Status - Controller Running in Demo Mode	state	0	1	-	0 = Normal Mode, 1 = Demo Mode

PLC Modbus Address	R/W	Function	Units	Min	Max	Def.	Notes
30001	R	Dewpoint in °F	°F	-148	68	-	
30002	R	Inlet Temperature in °F	°F	-348	9999	-	9999 = sensor open fault
30003	R	Inlet Pressure in psi	psi	0	200	-	
30004	R	Tower Pressure - Left Tower in psi	psi	0	200	-	
30005	R	Tower Pressure - Right Tower in psi	psi	0	200	-	
30006	R	Outlet Pressure in psi	psi	0	200	-	
30007	R	Inlet Differential Pressure	psid	0	200	-	
30008	R	Outlet Differential Pressure	psid				
30009	R	Tower Differential Pressure	psid	0	200	-	psid = left pressure - right pressure
30010	R	Dewpoint in °C	°C	-100	20	-	
30011	R	Inlet Temperature in °C	°C	-210	9999	-	9999 = sensor open fault
30012	R	Inlet Pressure in barx10	barx10	0	137	-	
30013	R	Tower Pressure - Left Tower in barx10	barx10	0	137	-	
30014	R	Tower Pressure - Right Tower in barx10	barx10	0	137	-	
30015	R	Outlet Pressure in barx10	barx10	0	137	-	
30016	R	Inlet Differential Pressure	bardx10	-137	137	-	
30017	R	Outlet Differential Pressure	bardx10	-137	137	-	
30018	R	Tower Differential Pressure	bardx10	-137	137	-	
30019	R	reserved				-	
30020	R	State		0	13	-	
30021	R	Aux Temperature Input in °F	°F			-	
30022	R	reserved				-	
30023	R	reserved				-	
30024-30025	R	Regeneration Time Remaining	secs			-	Double Integer
30026-30027	R	Repressurization Time Remaining	secs			-	Double Integer
30028-30029	R	Drying Time Remaining	secs			-	Double Integer
30030	R	Filter Days Remaining	Days	0	-	-	
30031	R	Model Configuration	-	0	1	-	0 = TP2671, 1 = TP2672

PLC Modbus Address	R/W	Function	Units	Min	Max	Def.	Notes
30032-30033	R	Total Run Hours	1/10th hour	0	9999999	-	Double Integer
30034-30035	R	Total Hours in Dewpoint Demand	1/10th hour	0	9999999	-	Double Integer
30036-30037	R	Total Count	counts	0	999999	-	Double Integer
40001	R/W	Control Set - Variable Cycle Dewpoint Threshold	°F	-100	20	-40	
40002	R/W	Alarm Set - High Dewpoint	°F	-80	50	-20	
40003	R/W	Alarm Set - Low Inlet Pres	psi	20	100	60	
40004	R/W	Alarm Set - High Inlet Temperature (°F)	°F	50	150	101	
40005	R/W	Alarm Set - Filter Days	days	0	365	180	
40006	R/W	Control Set - Drain Interval	Mins	1	60	10	Open drain every x minutes.
40007	R/W	Control Set - Drain Duration	secs	1	10	5	Open drain for x seconds.
40008	R/W	Control Set - Timing Configuration	-	1	6	1	1 = 10min, 2 = 15 min, 3 = 20 min, 4 = 4 min,
40009	R/W	Inlet Temperature Offset(°F)	°F	-10	10	0	
40010	R/W	Pressure Sensor Range	psi	100	800		
40011	R/W	Inlet Pressure Offset	psi	-15	15	0	
40012	R/W	Outlet Pressure Offset	psi	-15	15	0	
40013	R/W	Left Pressure Offset	psi	-15	15	0	
40014	R/W	Right Pressure Offset	psi	-15	15	0	
40015	R/W	Dewpoint Offset(°F)	°F	-36	36	0	
40016	R/W	Dewpoint Range Minimum(°F)	°F	-238	-4	-148	
40017	R/W	Dewpoint Range Maximum(°F)	°F	-4	86	68	
40018	R/W	Alarm Set - Inlet Filter Pressure	psid	0	15	8	
40019	R/W	Alarm Set - Outlet Filter Pressure	psid	0	15	8	



State Table (Modbus Register 30020)

State	Description
1	CLOSE LEFT INLET
2	REGENERATE LEFT / DRYING RIGHT
3	REPRESSURIZE LEFT / DRYING RIGHT
4	OPEN LEFT INLET
5	CLOSE RIGHT INLET
6	REGENERATE RIGHT / DRYING LEFT
7	REPRESSURIZE RIGHT / DRYING LEFT
8	OPEN RIGHT INLET
9	EXTENDED DRYING LEFT
10	EXTENDED DRYING RIGHT
11	REMOTE COMPRESSOR LOCK
12	STANDBY
13	WAITING FOR SYSTEM PRESSURE

## 18.2 Setting Static IP Address

The dryer is shipped with the IP address set to DHCP. This can be changed to a static IP address using the following instructions.

**NOTE:** Once the mode has been changed to STATIC, it can not be changed back to DHCP. Steps to change the Static IP address

1. Create a text file with the name ConfigMeFirst.txt with the following lines (exactly), with your IP, Mask, and Gateway settings. Do not alter this format.

(Copy the following lines into a text file and edit them to the desired configuration)

[PM] # Set to program mode (DO NOT CHANGE THIS LINE)

[CF] # clear any faults (DO NOT CHANGE THIS LINE)

[IPA=192.168.0.2] # set IP Address

[SNM=255.255.255.0] # Set mask

[GWA=0.0.0.0] # Set Gateway Address

[END] # Must be included (DO NOT CHANGE THIS LINE)

2. Copy the ConfigMeFirst.txt file to a blank Micro SD Card
3. Insert SD Card in PLC (Right hand side)
4. Restart the PLC by cycling power
5. Wait for the RUN light to go on
  - a. RUN Light Solid – Settings failed to load. Check the ConfigMeFirst.txt file and try again
  - b. RUN Light Blinking – IP Address has successfully been set
6. Remove the SD Card
7. Restart the PLC by cycling power

### 18.3 Modbus/RTU Option

#### RS232 or RS485 Communications

If the dryer must be connected to an RS485 network or RS232 port, use a Modbus Gateway device such as SW2400-MB3170.

#### CONFIGURING SW2400-MB3170 MODBUS-TCP TO MODBUS-RTU OPTION

Refer to CONFIGURING STATIC IP ADDRESS to change the IP address of the dryer’s PLC to:

IP Address: 192.168.10.2  
 Subnet Mask: 255.255.255.0  
 Gateway: 0.0.0.0  
 DNS: 0.0.0.0

The MGate Manager software that comes with the gateway is used to change the configuration. Additionally, the MGate Manager software can be downloaded from the Moxa website.

1. Install the MGate Manager software included on the CD that came with the gateway
2. Connect the Gateway to the Ethernet and power up the device
3. Select Search and choose Broadcast Search to find the device on the network

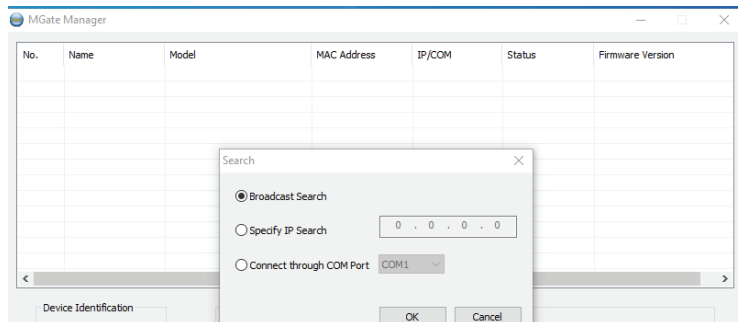

4. Highlight the device and select Configuration

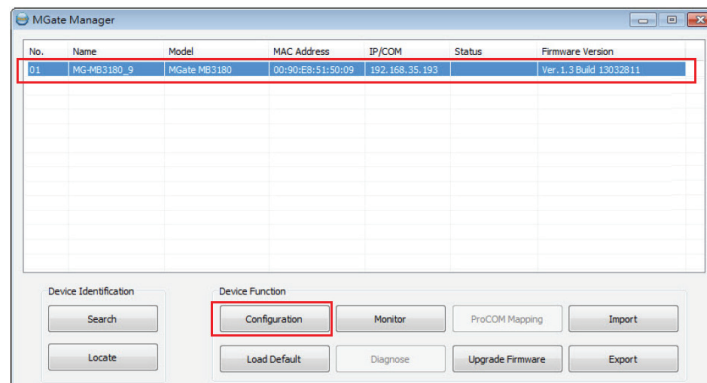



### 5. Select RTU Master Mode

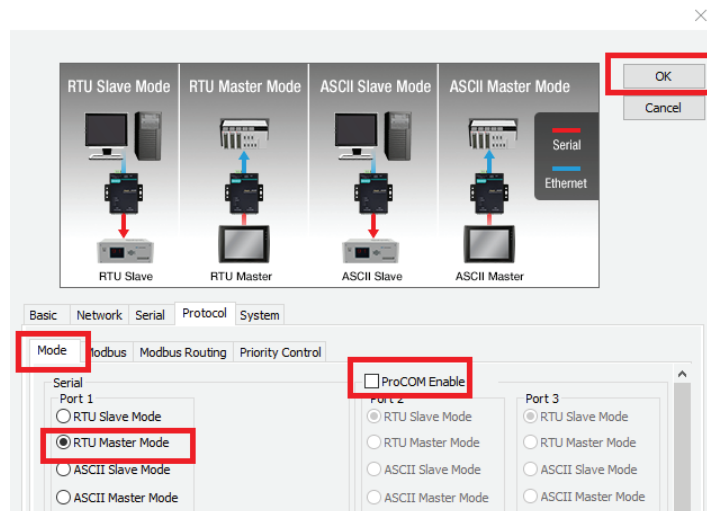

### 6. Configure Network as follows:

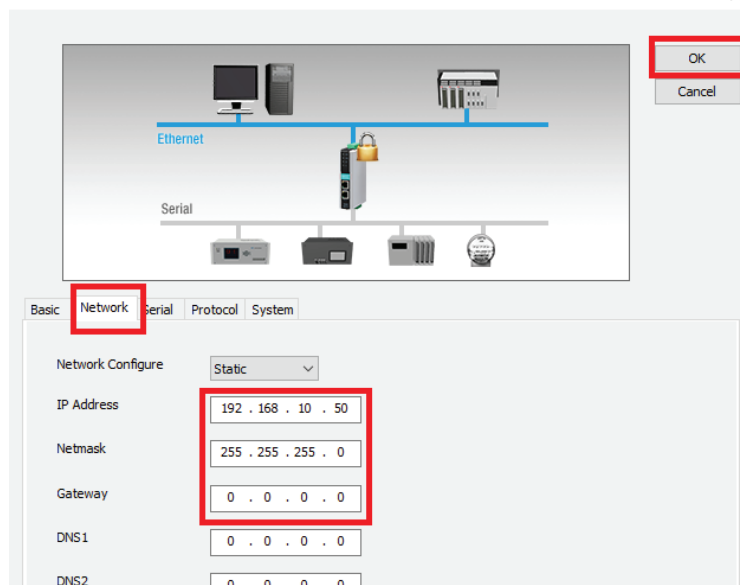

## 7. Modbus Routing

The example shows the settings for a dryer which has been assigned a slave address of 1. Set the Slave ID Start and Slave ID End settings to the slave address that your network administrator has assigned to the dryer on your MODBUS-RTU network. Both settings must be the same. If more than one piece of equipment in on the network, they must all have their own unique address.

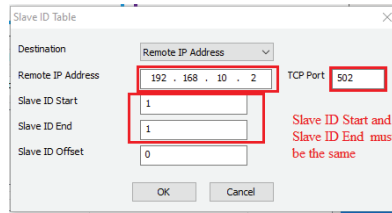

## 8. Serial Port Configuration - Set the serial port settings to match your RS485 network

No further settings are required to the device gateway

**NOTE:** Once you have everything working, you can use the EXPORT and IMPORT keys on the initial configuration screen to save your settings to easily replicate them on another dryer on the network (don't forget to select a unique slave address for each dryer).

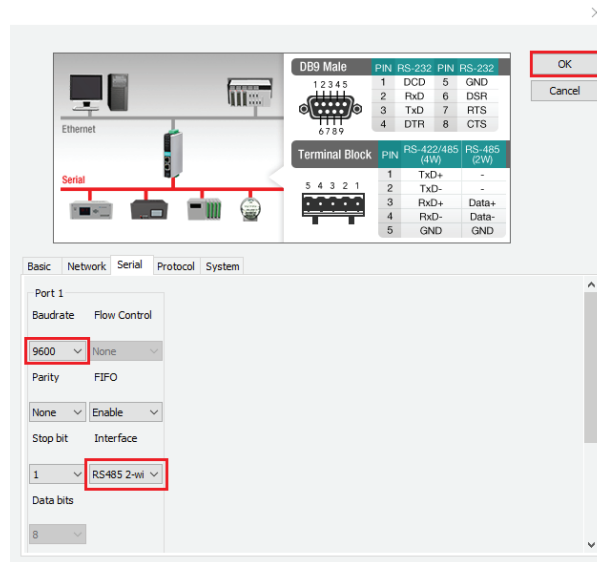

## 19. VOICE OF THE MACHINE



### Voice of the Machine IoT Capability

Parker's Voice of the Machine platform is a cloud-based remote monitoring interface that provides operating status, data trends, communicates alarms via email or text alerts and analytics for increased awareness of your assets.

- Available with Advanced Controller only.
- Utilizes Cellular Networks to Communicate.
- Communicates local data to the cloud in real time.
- Displays when the dryer has an active alarm or is in Powerloc Energy Savings mode.
- Alerts & Notifications can be set in a manner that makes sense to the customer.

For more information on Voice of the Machine, Contact your Parker Compressed Air Products representative.

## 20. MAINTENANCE INTERVALS

Component	Operation	Daily	Weekly	Monthly	6 months	12 months
Filter Drains	Check for proper drain operation					
Exhaust Mufflers	Verify there is no backpressure on regenerating tank. Clean or replace clogged exhaust mufflers as needed.					
Pre/After Filters	Replace filter elements					
Desiccant	Check desiccant quality. Replacement is recommended every 3-5 years.					
Control Air Filter	Replace filter element					
Switching Valves	Check condition annually. Refer to maintenance kits for service intervals.					
Check Valves	Check condition. Refer to maintenance kits for service intervals.					

= Check

= Service

## 21. MAINTENANCE KITS

12 Month Maintenance Kit	Model	Maintenance Kit Contents					
		Mufflers (2 each)	Control Air Filter (1 Each)	Pre Filters	Pre Filters (QTY)	After Filters	After Filters (QTY)
MK12-TW55	TW55	TP4203-1 (QTY 1)	TP2201-PE	P020AA	1	P020AO	1
MK12-TW100	TW100	TP4210-1	TP2201-PE	P025AA	1	P025AO	1
MK12-TW130	TW130	TP4210-1	TP2201-PE	P025AA	1	P025AO	1
MK12-TW200	TW200	TP4210-1	TP2201-PE	P030AA	1	P030AO	1
MK12-TW250	TW250	TP4210-1	TP2201-PE	P035AA	1	P035AO	1
MK12-TW300	TW300	TP4210-1	TP2201-PE	P035AA	1	P035AO	1
MK12-TW400	TW400	TP4215-1	TP2201-PE	P040AA	1	P040AO	1
MK12-TW500	TW500	TP4215-1	TP2201-PE	P045AA	1	P045AO	1
MK12-TW600	TW600	TP4215-1	TP2201-PE	P045AA	1	P045AO	1
MK12-TW800	TW800	TP4215-1	TP2201-PE	P050AA	1	P050AO	1
MK12-TW1000	TW1000	TP4230-RK	TP2201-PE	P055AA	1	P055AO	1
MK12-TW1200	TW1200	TP4230-RK	TP2201-PE	P055AA	1	P055AO	1
MK12-TW1500	TW1500	TP4230-RK	TP2201-PE	P060AA	3	JC1010-FH	1
MK12-TW2000	TW2000	TP4230-RK	TP2201-PE	P060AA	3	P060AO	3
MK12-TW2600	TW2600	TP4230-RK	TP2201-PE	JE-C3001	1	JE-FC3320-HT	1
MK12-TW3000	TW3000	TP4230-RK	TP2201-PE	JE-C3001	1	JE-FC3320-HT	1

24 Month Maintenance Kit	Model	Maintenance Kit Contents									
		Bray Inlet Butterfly Valve Repair Kits (2 each)	Bray Exhaust Butterfly Valve Repair Kits (2 each)	Inlet Valve (1 each)	Exhaust Valve (1 Each)	Outlet Check Valve (2 Each)	Purge Check Valve (2 Each)	Control Solenoids (QTY 4)	Control Solenoids (QTY 6)	Repress Valve (1 each)	Repress Control Solenoid (1 Each)
MK24-TW55	TW55	N/A	N/A	TP8277-P	TP8003	TP7407-AB	TP7403-AB	N/A	N/A	N/A	N/A
MK24-TW100	TW100	N/A	N/A	N/A	N/A	N/A	N/A	TP8101-1D	N/A	TP8002	N/A
MK24-TW130	TW130	N/A	N/A	N/A	N/A	N/A	N/A	TP8101-1D	N/A	TP8002	N/A
MK24-TW200	TW200	N/A	N/A	N/A	N/A	N/A	N/A	TP8101-1D	N/A	TP8002	N/A
MK24-TW250	TW250	N/A	N/A	N/A	N/A	N/A	N/A	TP8101-1D	N/A	TP8002	N/A
MK24-TW300	TW300	N/A	N/A	N/A	N/A	N/A	N/A	TP8101-1D	N/A	TP8002	N/A
MK24-TW400	TW400	N/A	N/A	N/A	N/A	N/A	N/A	TP8101-1D	N/A	TP8005	N/A
MK24-TW500	TW500	N/A	N/A	N/A	N/A	N/A	N/A	TP8101-1D	N/A	TP8005	N/A
MK24-TW600	TW600	N/A	N/A	N/A	N/A	N/A	N/A	TP8101-1D	N/A	TP8005	N/A
MK24-TW800	TW800	N/A	N/A	N/A	N/A	N/A	N/A	TP8101-1D	N/A	TP8005	N/A
MK24-TW1000	TW1000	TP7631-BD-HP-RK	N/A	N/A	N/A	N/A	N/A	TP8101-1D	N/A	TP8101-D	TP8101-D
MK24-TW1200	TW1200	TP7631-BD-HP-RK	N/A	N/A	N/A	N/A	N/A	TP8101-1D	N/A	TP8101-D	TP8101-D
MK24-TW1500	TW1500	TP7631-BD-HP-RK	N/A	N/A	N/A	N/A	N/A	TP8101-1D	N/A	TP8101-D	TP8101-D
MK24-TW2000	TW2000	TP7641-BD-HP-RK	N/A	N/A	N/A	N/A	N/A	TP8101-1D	N/A	TP8101-D	TP8101-D
MK24-TW2600	TW2600	TP7641-BD-HP-RK	TP7631-BD-HP-RK	N/A	N/A	N/A	N/A	TP8101-1D	N/A	TP8101-D	TP8101-D
MK24-TW3000	TW3000	TP7641-BD-HP-RK	TP7631-BD-HP-RK	N/A	N/A	N/A	N/A	TP8101-1D	N/A	TP8101-D	TP8101-D

48 Month Maintenance Kit	Model	Maintenance Kit Contents				
		Inlet Valve (2 each)	Exhaust Valve (2 each)	Repress Valve (1 each)	Outlet Check Valve (2 each)	Purge Check Valve (2 each)
MK48-TW100	TW100	TP7610-KV	TP7510-KV	N/A	TP7410-KV	TP7405-KV
MK48-TW130	TW130	TP7610-KV	TP7510-KV	N/A	TP7410-KV	TP7405-KV
MK48-TW200	TW200	TP7615-KV	TP7510-KV	N/A	TP7415-KV	TP7405-KV
MK48-TW250	TW250	TP7615-KV	TP7510-KV	N/A	TP7415-KV	TP7405-KV
MK48-TW300	TW300	TP7615-KV	TP7510-KV	N/A	TP7415-KV	TP7405-KV
MK48-TW400	TW400	TP7620-KV	TP7515-KV	N/A	TP7420-KV	TP7407-KV
MK48-TW500	TW500	TP7620-KV	TP7515-KV	N/A	TP7420-KV	TP7407-KV
MK48-TW600	TW600	TP7620-KV	TP7515-KV	N/A	TP7420-KV	TP7407-KV
MK48-TW800	TW800	TP7620-KV	TP7515-KV	N/A	TP7420-KV	TP7407-KV
MK48-TW1000	TW1000	N/A	TP7515-KV	TP7610-KV	TP7431-SW	TP7410-KV
MK48-TW1200	TW1200	N/A	TP7520-KV	TP7610-KV	TP7431-SW	TP7415-KV
MK48-TW1500	TW1500	N/A	TP7520-KV	TP7610-KV	TP7431-SW	TP7415-KV
MK48-TW2000	TW2000	N/A	TP7520-KV	TP7610-KV	TP7441-SW	TP7415-KV
MK48-TW2600	TW2600	N/A	N/A	TP7610-KV	TP7441-SW	TP7431-SW
MK48-TW3000	TW3000	N/A	N/A	TP7610-KV	TP7441-SW	TP7431-SW



## 22. SPARE PARTS LISTS

Spare Parts Description	MODEL	TW0055
<b>DESICCANT</b>	<b>PART ID</b>	<b>Part Number</b>
DESICCANT 25LB BAGS (QTY)	AV1, AV2	PDA-1/8-25 (4)
<b>FILTER ELEMENTS</b>		
PREFILTER ELEMENT (QTY)	PF1	P020AA (1)
AFTERFILTER ELEMENT (QTY)	AF1	P020AO (1)
CONTROL AIR FILTER ELEMENT (QTY)	CF1	TP2201-PE (1)
<b>REPLACEMENT PARTS</b>		
INLET VALVE	PV2	TP8277-P
EXHAUST VALVE	PV1	TP8003
OUTLET CHECK VALVE	CV1, CV2	TP7407-AB
PURGE CHECK VALVE	CV3, CV4	TP7403-AB
PURGE VALVE	NV1	TP7025
REPRESSURIZATION VALVE	S5	N/A
CONTROL SOLENOID VALVE	S1, S2, S3, S4	N/A
EXHAUST MUFFLER	ES1	TP4203-1
CONTROL AIR FILTER	CF1	TP2201-P
SAFETY RELIEF VALVE	PSV1, PSV2	TP7102-1
PRESSURE GAUGE	PI1, PI2, PI3	LP1020
PURGE ORIFICE	RO1	TP4412-0215
<b>MODELS WITH BASIC CONTROLLER OPTION</b>		
DRAIN - PRE FILTER	FD1	M12.FD.0001
DRAIN - AFTER FILTER	FD2	EM1
PLC & DISPLAY	PLC	TP2662-PLC
PLC DISPLAY ONLY	LCD	2080-LCD
RELAY	CR1	TP2581-S-120VAC
FUSE, 2 AMP, TIME DELAY	F1	EF0200-2-TD
<b>MODELS WITH BASIC PLUS CONTROLLER OPTION</b>		
DRAIN - PRE FILTER	FD1	M12.FD.0001
DRAIN - AFTER FILTER	FD2	EM1
DEWPOINT PROBE	AE1	TP2190-1-UL
PLC & DISPLAY	PLC	TP2667-PLC
PLC DISPLAY ONLY	LCD	2080-LCD
RELAY	CR1, CR2	TP2581-S-120VAC
POWER SUPPLY	PS1	TP2500-PS24-15W
PRESSURE SWITCH	PL, PR	TP2320
FUSE, 2 AMP, TIME DELAY	F1	EF0200-2-TD
REMOTE DEWPOINT ISOLATOR OPTION		TP2189-2

Refer to drawing #TW0055-BB11NNF-MAN in section 22 below

Spare Parts Description	MODEL	TW0100	TW0130	TW0200	TW0250	TW0300
<b>DESICCANT</b>	<b>PART ID</b>	<b>Part Number</b>				
DESICCANT 25LB BAGS (QTY)	AV1, AV2	PDA-1/8-25 (6)	PDA-1/8-25 (8)	PDA-1/8-25 (10)	PDA-1/8-25 (12)	PDA-1/8-25 (14)
<b>FILTER ELEMENTS</b>						
PREFILTER ELEMENT (QTY)	PF1	P025AA (1)	P025AA (1)	P030AA (1)	P035AA (1)	P035AA (1)
AFTERFILTER ELEMENT (QTY)	AF1	P025AO (1)	P025AO (1)	P030AO (1)	P035AO (1)	P035AO (1)
CONTROL AIR FILTER ELEMENT (QTY)	CF1	TP2201-PE (1)	TP2201-PE (1)	TP2201-PE (1)	TP2201-PE (1)	TP2201-PE (1)
<b>REPLACEMENT PARTS</b>						
INLET VALVE	PV2, PV3	TP7610-KV	TP7610-KV	TP7615-KV	TP7615-KV	TP7615-KV
EXHAUST VALVE	PV1, PV4	TP7510-KV	TP7510-KV	TP7510-KV	TP7510-KV	TP7510-KV
OUTLET CHECK VALVE	CV1, CV2	TP7410-KV	TP7410-KV	TP7415-KV	TP7415-KV	TP7415-KV
PURGE CHECK VALVE	CV3, CV4	TP7405-KV	TP7405-KV	TP7405-KV	TP7405-KV	TP7405-KV
PURGE REGULATOR	PR1	P31RB92NNHP	P31RB92NNHP	P31RB92NNHP	P31RB92NNHP	P31RB92NNHP
REPRESSURIZATION VALVE	S5	TP8002	TP8002	TP8002	TP8002	TP8002
CONTROL SOLENOID VALVE	S1, S2, S3, S4	TP8101-1D	TP8101-1D	TP8101-1D	TP8101-1D	TP8101-1D
EXHAUST MUFFLER	ES1, ES2	TP4210-2	TP4210-2	TP4210-2	TP4210-2	TP4210-2
CONTROL AIR FILTER	CF1	TP2201-P	TP2201-P	TP2201-P	TP2201-P	TP2201-P
SAFETY RELIEF VALVE	PSV1, PSV2	TP7105	TP7105	TP7105	TP7105	TP7105
PRESSURE GAUGE	PI1, PI2, PI3	LP1020	LP1020	LP1020	LP1020	LP1020
PURGE ORIFICE	RO1	TP4418-0520	TP4418-0520	TP4425-0525	TP4431-0515	TP4431-0515
<b>MODELS WITH BASIC CONTROLLER OPTION</b>						
DRAIN - PRE FILTER	FD1			M12.FD.0001		
DRAIN - AFTER FILTER	FD2			EM1		
PLC & DISPLAY	PLC			TP2661-PLC		
PLC DISPLAY ONLY	LCD			2080-LCD		
RELAY	CR1			TP2581-S-120VAC		
FUSE, 2 AMP, TIME DELAY	F1			EF0200-2-TD		
<b>MODELS WITH BASIC PLUS CONTROLLER OPTION</b>						
DRAIN - PRE FILTER	FD1			M12.FD.0001		
DRAIN - AFTER FILTER	FD2			EM1		
DEWPOINT PROBE	AE1			TP2190-1-UL		
PLC & DISPLAY	PLC			TP2666-PLC		
PLC DISPLAY ONLY	LCD			2080-LCD		
RELAY	CR1, CR2			TP2581-S-120VAC		
POWER SUPPLY	PS1			TP2500-PS24-15W		
PRESSURE SWITCH	PL, PR			TP2320		
FUSE, 2 AMP, TIME DELAY	F1			EF0200-2-TD		
REMOTE DEWPOINT ISOLATOR OPTION				TP2189-2		
<b>MODELS WITH ADVANCED CONTROLLER OPTION</b>						
DRAIN - AFTER FILTER	FD2			EM1		
DRAIN - PRE FILTER	FD1			KP5025		
PRE FILTER DRAIN SOLENOID VALVE				TP8002		
DEWPOINT PROBE	AE1			TP2190-1-UL		
PLC				TP2671-PLC		
ANALOG INPUT MODULE	PLCA			2080-IF4		
HMI DISPLAY	HMI			TP267X-HMI		
HMI DISPLAY CABLE				TP267X-HMI-CBL		
POWER SUPPLY	PS1			TP2500-PS24-15W		
PRESSURE TRANSMITTER & CABLE	LP, RP, IP, OP			TP2452-200-KIT		
INLET NTC TEMPERATURE SENSOR	IT			TP2087-6-6		
FUSE, 1/8 AMP, FAST ACTING	F2			EF0012		
FUSE, 2 AMP, TIME DELAY	F1			EF0200-2-TD		
MEMORY CARD				TP265X-SD		
REMOTE DEWPOINT ISOLATOR OPTION				TP2189-2		

Refer to drawing #TW0100-BB11NNF-MAN in section 22 below



Spare Parts Description	MODEL	TW0400	TW0500	TW0600	TW0800
<b>DESICCANT</b>					
DESICCANT 25LB BAGS (QTY)	AV1, AV2	PDA-1/8-25 (20)	PDA-1/8-25 (24)	PDA-1/8-25 (28)	PDA-1/8-25 (38)
<b>FILTER ELEMENTS</b>					
PREFILTER ELEMENT (QTY)	PF1	P040AA (1)	P045AA (1)	P045AA (1)	P050AA (1)
AFTERFILTER ELEMENT (QTY)	AF1	P040AO (1)	P045AO (1)	P045AO (1)	P050AO (1)
CONTROL AIR FILTER ELEMENT (QTY)	CF1	TP2201-PE (1)	TP2201-PE (1)	TP2201-PE (1)	TP2201-PE (1)
<b>REPLACEMENT PARTS</b>					
INLET VALVE	PV2, PV3	TP7620-KV	TP7620-KV	TP7620-KV	TP7620-KV
EXHAUST VALVE	PV1, PV4	TP7515-KV	TP7515-KV	TP7515-KV	TP7515-KV
OUTLET CHECK VALVE	CV1, CV2	TP7420-KV	TP7420-KV	TP7420-KV	TP7420-KV
PURGE CHECK VALVE	CV3, CV4	TP7407-KV	TP7407-KV	TP7407-KV	TP7407-KV
PURGE REGULATOR	PR1	TP4605	TP4605	P33RA96NNHP	P33RA96NNHP
REPRESSURIZATION VALVE	S5	TP8005	TP8005	TP8005	TP8005
CONTROL SOLENOID VALVE	S1, S2, S3, S4	TP8101-1D	TP8101-1D	TP8101-1D	TP8101-1D
EXHAUST MUFFLER	ES1, ES2	TP4215-2	TP4215-2	TP4215-2	TP4215-2
CONTROL AIR FILTER	CF1	TP2201-P	TP2201-P	TP2201-P	TP2201-P
SAFETY RELIEF VALVE	PSV1, PSV2	TP7105	TP7105	TP7105	TP7105
PRESSURE GAUGE	PI1, PI2, PI3	LP1020	LP1020	LP1020	LP1020
PURGE ORIFICE	RO1	TP4437-0520	TP4437-0520	TP4443-1020	TP4443-1020
<b>MODELS WITH BASIC CONTROLLER OPTION</b>					
DRAIN - PRE FILTER	FD1		M12.FD.0001		
DRAIN - AFTER FILTER	FD2		EM1		
PLC & DISPLAY	PLC		TP2661-PLC		
PLC DISPLAY ONLY	LCD		2080-LCD		
RELAY	CR1		TP2581-S-120VAC		
FUSE, 2 AMP, TIME DELAY	F1		EF0200-2-TD		
<b>MODELS WITH BASIC PLUS CONTROLLER OPTION</b>					
DRAIN - PRE FILTER	FD1		M12.FD.0001		
DRAIN - AFTER FILTER	FD2		EM1		
DEWPOINT PROBE	AE1		TP2190-1-UL		
PLC & DISPLAY	PLC		TP2666-PLC		
PLC DISPLAY ONLY	LCD		2080-LCD		
RELAY	CR1, CR2		TP2581-S-120VAC		
POWER SUPPLY	PS1		TP2500-PS24-15W		
PRESSURE SWITCH	PL, PR		TP2320		
FUSE, 2 AMP, TIME DELAY	F1		EF0200-2-TD		
REMOTE DEWPOINT ISOLATOR OPTION			TP2189-2		
<b>MODELS WITH ADVANCED CONTROLLER OPTION</b>					
DRAIN - AFTER FILTER	FD2		EM1		
DRAIN - PRE FILTER	FD1		KP5025		
PRE FILTER DRAIN SOLENOID VALVE			TP8002		
DEWPOINT PROBE	AE1		TP2190-1-UL		
PLC	PLC		TP2671-PLC		
ANALOG INPUT MODULE	PLCA		2080-IF4		
HMI DISPLAY	HMI		TP267X-HMI		
HMI DISPLAY CABLE			TP267X-HMI-CBL		
POWER SUPPLY	PS1		TP2500-PS24-15W		
PRESSURE TRANSMITTER & CABLE	LP, RP, IP, OP		TP2452-200-KIT		
INLET NTC TEMPERATURE SENSOR	IT		TP2087-6-6		
FUSE, 1/8 AMP, FAST ACTING	F2		EF0012		
FUSE, 2 AMP, TIME DELAY	F1		EF0200-2-TD		
MEMORY CARD			TP265X-SD		
REMOTE DEWPOINT ISOLATOR OPTION			TP2189-2		

Refer to drawing #TW0100-BB11NNF-MAN in section 22 below



Spare Parts Description	MODEL	TW1000	TW1200
<b>DESICCANT</b>	<b>PART ID</b>	<b>Part Number</b>	
DESICCANT 25LB BAGS (QTY)	AV1, AV2	PDA-1/8-25 (48)	PDA-1/8-25 (58)
<b>FILTER ELEMENTS</b>			
PREFILTER ELEMENT (QTY)	PF1	P055AA (1)	P055AA (1)
AFTERFILTER ELEMENT (QTY)	AF1	P055AO (1)	P055AO (1)
CONTROL AIR FILTER ELEMENT (QTY)	CF1	TP2201-PE (1)	TP2201-PE (1)
<b>REPLACEMENT PARTS</b>			
INLET VALVE	PV2, PV3	TP7631-BD-HP	TP7631-BD-HP
INLET VALVE ACTUATOR	PV2, PV3	TP7631-BD-HP-A	TP7631-BD-HP-A
INLET VALVE REPAIR KIT	PV2, PV3	TP7631-BD-HP-RK	TP7631-BD-HP-RK
EXHAUST VALVE	PV1, PV4	TP7515-KV	TP7520-KV
OUTLET CHECK VALVE	CV1, CV2	TP7431-SW	TP7431-SW
PURGE CHECK VALVE	CV3, CV4	TP7410-KV	TP7415-KV
PURGE REGULATOR	PR1	TP4610	TP4610
REPRESSURIZATION VALVE	PV5	TP7610-KV	TP7610-KV
REPRESS CONTROL SOLENOID	S5	TP8101-D	TP8101-D
CONTROL SOLENOID VALVE	S1,S2,S3,S4,S7,S8	TP8101-1D	TP8101-1D
EXHAUST MUFFLER CORE REPLACEMENT	ES1, ES2	TP4230-RK-1	TP4230-RK-1
EXHAUST MUFFLER	ES1, ES2	TP4230-3	TP4230-3
CONTROL AIR FILTER	CF1	TP2201-P	TP2201-P
SAFETY RELIEF VALVE	PSV1, PSV2	TP7105	TP7105
PRESSURE GAUGE	PI1, PI2, PI3	LP1020	LP1020
PURGE ORIFICE	RO1	TP4450-1025	TP4463-1525
<b>MODELS WITH BASIC CONTROLLER OPTION</b>			
DRAIN - PRE FILTER	FD1	M12.FD.0001	
DRAIN - AFTER FILTER	FD2	EM1	
PLC & DISPLAY		TP2663-PLC	
PLC DISPLAY ONLY	LCD	2080-LCD	
RELAY	CR1	TP2581-S-120VAC	
FUSE, 2 AMP, TIME DELAY	F1	EF0200-2-TD	
<b>MODELS WITH BASIC PLUS CONTROLLER OPTION</b>			
DRAIN - PRE FILTER	FD1	M12.FD.0001	
DRAIN - AFTER FILTER	FD2	EM1	
DEWPOINT PROBE	AE1	TP2190-1-UL	
PLC & DISPLAY	PLC	TP2668-PLC	
PLC DISPLAY ONLY	LCD	2080-LCD	
RELAY	CR1, CR2	TP2581-S-120VAC	
POWER SUPPLY	PS1	TP2500-PS24-15W	
PRESSURE SWITCH	PL, PR	TP2320	
FUSE, 2 AMP, TIME DELAY	F1	EF0200-2-TD	
REMOTE DEWPOINT ISOLATOR OPTION		TP2189-2	
<b>MODELS WITH ADVANCED CONTROLLER OPTION</b>			
DRAIN - AFTER FILTER	FD2	EM1	
DRAIN - PRE FILTER		KP5050	
PRE FILTER DRAIN SOLENOID VALVE	FD1	TP8002	
DEWPOINT PROBE	AE1	TP2190-1-UL	
PLC	PLC	TP2672-PLC	
ANALOG INPUT MODULE	PLCA	2080-IF4	
HMI DISPLAY	HMI	TP267X-HMI	
HMI DISPLAY CABLE		TP267X-HMI-CBL	
POWER SUPPLY	PS1	TP2500-PS24-15W	
PRESSURE TRANSMITTER & CABLE	LP, RP, IP, OP	TP2452-200-KIT	
INLET THERMOCOUPLE	IT	TP2087-6-6	

Refer to drawing #TW1200-BB11NNF-MAN in section 22 below





Spare Parts Description	MODEL	TW1500	TW2000	TW2600	TW3000
<b>DESICCANT</b>	<b>PART ID</b>	<b>Part Number</b>			
DESICCANT 25LB BAGS (QTY)	AV1, AV2	PDA-1/8-25 (72)	PDA-1/8-25 (96)	PDA-1/8-25 (124)	PDA-1/8-25 (144)
<b>FILTER ELEMENTS</b>					
PREFILTER ELEMENT (QTY)	PF1	P055AA (1 Per Housing)	P055AA (1 Per Housing)	JE-C3001 (1)	JE-C3001 (1)
AFTERFILTER ELEMENT (QTY)	AF1	JE-FC1660-HT (1)	P055AO (1 Per Housing)	JE-FC3320-HT (1)	JE-FC3320-HT (1)
CONTROL AIR FILTER ELEMENT (QTY)	CF1	TP2201-PE (1)	TP2201-PE (1)	TP2201-PE (1)	TP2201-PE (1)
<b>REPLACEMENT PARTS</b>					
INLET VALVE	PV2, PV3	TP7631-BD-HP	TP7641-BD-HP	TP7641-BD-HP	TP7641-BD-HP
INLET VALVE ACTUATOR	PV2, PV3	TP7631-BD-HP-A	TP7631-BD-HP-A	TP7631-BD-HP-A	TP7631-BD-HP-A
INLET VALVE REPAIR KIT	PV2, PV3	TP7631-BD-HP-RK	TP7641-BD-HP-RK	TP7641-BD-HP-RK	TP7641-BD-HP-RK
EXHAUST VALVE	PV1, PV4	TP7520-KV	TP7520-KV	TP7532-B-HP	TP7532-B-HP
EXHAUST VALVE REPAIR KIT	PV1, PV4	N/A	N/A	TP7631-BD-HP-RK	TP7631-BD-HP-RK
EXHAUST VALVE ACTUATOR	PV1, PV4	N/A	N/A	TP7532-B-HP-A	TP7532-B-HP-A
OUTLET CHECK VALVE	CV1, CV2	TP7431-SW	TP7441-SW	TP7441-SW	TP7441-SW
PURGE CHECK VALVE	CV3, CV4	TP7415-KV	TP7415-KV	TP7431-SW	TP7431-SW
PURGE REGULATOR	PR1	TP4615	TP4615	TP4615	TP4615
REPRESSURIZATION VALVE	PV5	TP7610-KV	TP7610-KV	TP7610-KV	TP7610-KV
REPRESS CONTROL SOLENOID	S5	TP8101-D	TP8101-D	TP8101-D	TP8101-D
CONTROL SOLENOID VALVE	S1,S2,S3,S4,S7,S8	TP8101-1D	TP8101-1D	TP8101-1D	TP8101-1D
EXHAUST MUFFLER CORE REPLACEMENT	ES1, ES2	TP4230-RK-1	TP4230-RK-1	TP4230-RK-1	TP4230-RK-1
EXHAUST MUFFLER	ES1, ES2	TP4230-3	TP4230-3	TP4230-3	TP4230-3
CONTROL AIR FILTER	CF1	TP2201-P	TP2201-P	TP2201-P	TP2201-P
SAFETY RELIEF VALVE	PSV1, PSV2	TP7110	TP7120	TP7120	TP7120
PRESSURE GAUGE	PI1, PI2	LP1020	LP1045	LP1045	LP1045
PRESSURE GAUGE	PI3	LP1020	LP1020	LP1020	LP1020
PURGE ORIFICE	RO1	TP4463-1525	TP4475-1530	TP4475-1530	TP4499-1530-F
VESSEL MANWAY GASKET		N/A	FM21216-G	FM21216-G	FM21216-G
<b>MODELS WITH BASIC CONTROLLER OPTION</b>					
DRAIN - PRE FILTER	FD1	TSD-050 (1 Per Housing)	TSD-050 (1 Per Housing)	TSD-050 (2)	TSD-050 (2)
DRAIN - AFTER FILTER	FD2	N/A	EM1 (1 Per Housing)	TP7202	TP7202
PLC & DISPLAY	PLC		TP2663-PLC		
PLC DISPLAY ONLY	LCD		2080-LCD		
RELAY	CR1		TP2581-S-120VAC		
FUSE, 2 AMP, TIME DELAY	F1		EF0200-2-TD		
<b>MODELS WITH BASIC PLUS CONTROLLER OPTION</b>					
DRAIN - PRE FILTER	FD1	TSD-050 (1 Per Housing)	TSD-050 (1 Per Housing)	TSD-050 (2)	TSD-050 (2)
DRAIN - AFTER FILTER	FD2	N/A	EM1 (1 Per Housing)	TP7202	TP7202
DEWPOINT PROBE	AE1		TP2190-1-UL		
PLC	PLC		TP2668-PLC		
HMI DISPLAY	LCD		2080-LCD		
RELAY	CR1, CR2		TP2581-S-120VAC		
POWER SUPPLY	PS1		TP2500-PS24-15W		
PRESSURE SWITCH	PL, PR		TP2320		
FUSE, 2 AMP, TIME DELAY	F1		EF0200-2-TD		
REMOTE DEWPOINT ISOLATOR OPTION			TP2189-2		
<b>MODELS WITH ADVANCED CONTROLLER OPTION</b>					
DRAIN - PRE FILTER	FD1		KP5050 (1 per filter)		KP5050 (2)
PRE FILTER DRAIN SOLENOID VALVE			TP8002 (1 per filter)		TP8002 (2)
DEWPOINT PROBE	AE1		TP2190-1-UL		
PLC	PLC		TP2672-PLC		
ANALOG INPUT MODULE	PLCA		2080-IF4		
OUTPUT MODULE	PLCB		2080-OW4I		
HMI DISPLAY	HMI		TP267X-HMI		
HMI DISPLAY CABLE			TP267X-HMI-CBL		
POWER SUPPLY	PS1		TP2500-PS24-15W		
PRESSURE TRANSMITTER & CABLE	LP, RP, IP, OP		TP2452-200-KIT		
INLET NTC TEMPERATURE SENSOR	IT		TP2087-6-6		
FUSE, 1/8 AMP, FAST ACTING	F2		EF0012		
FUSE, 2 AMP, TIME DELAY	F1		EF0200-2-TD		
MEMORY CARD			TP265X-SD		
REMOTE DEWPOINT ISOLATOR OPTION			TP2189-2		

Refer to drawing #TW3000-BB11NNF-MAN in section 22 below



## 23. DRAWINGS

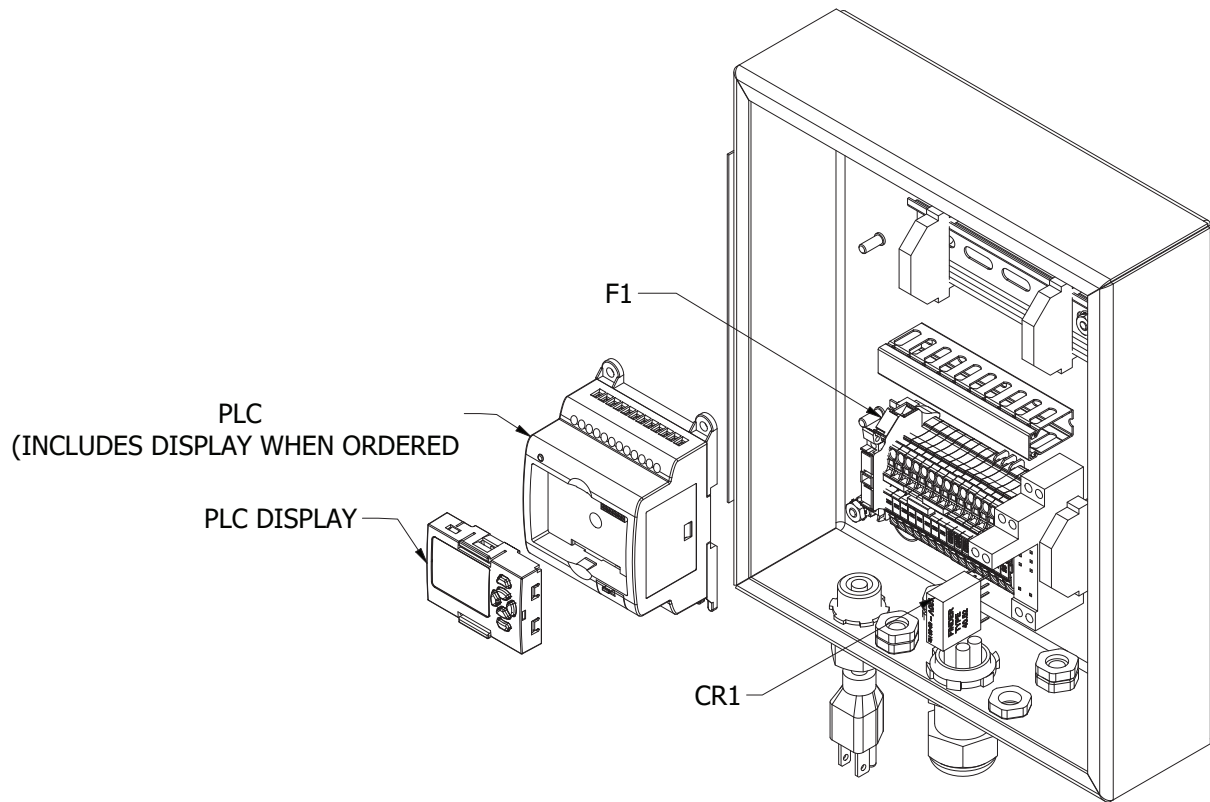

TP2661-PARTS-MAN

## BASIC CONTROLLER

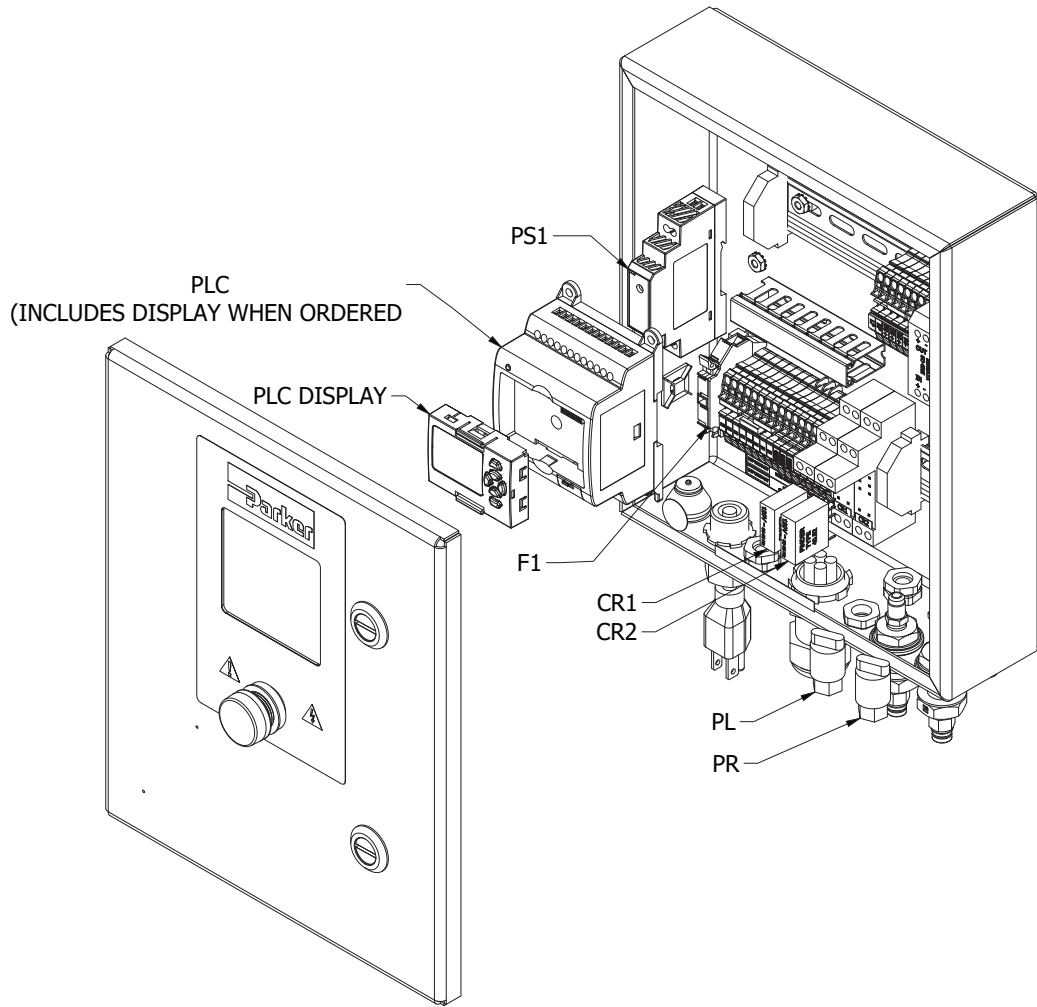

## BASIC PLUS CONTROLLER

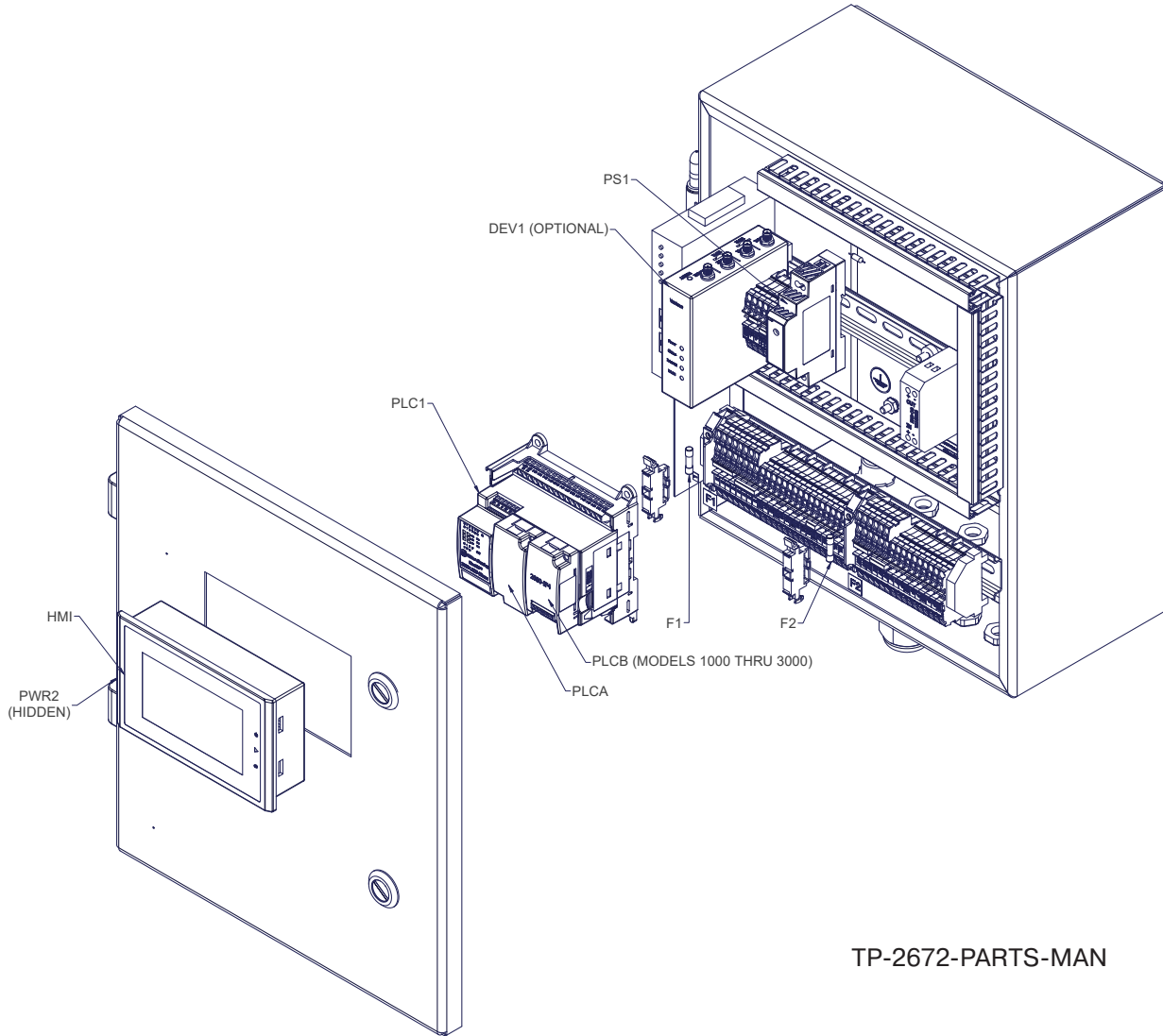

TP-2672-PARTS-MAN

## ADVANCED CONTROLLER

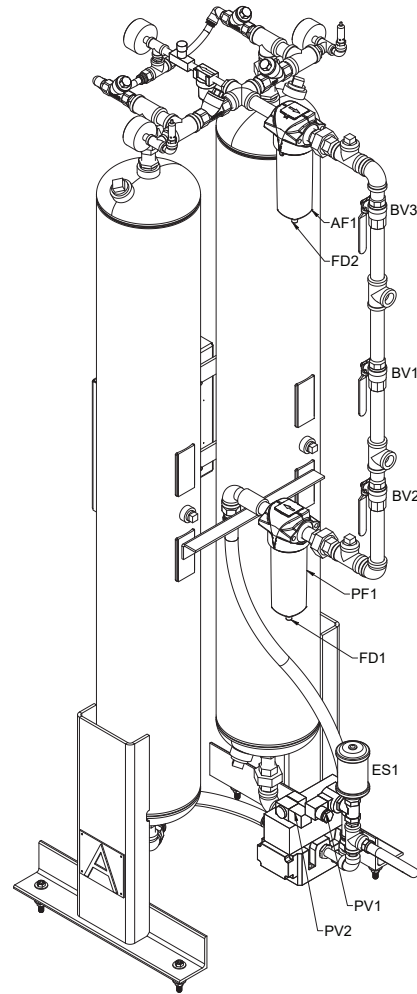
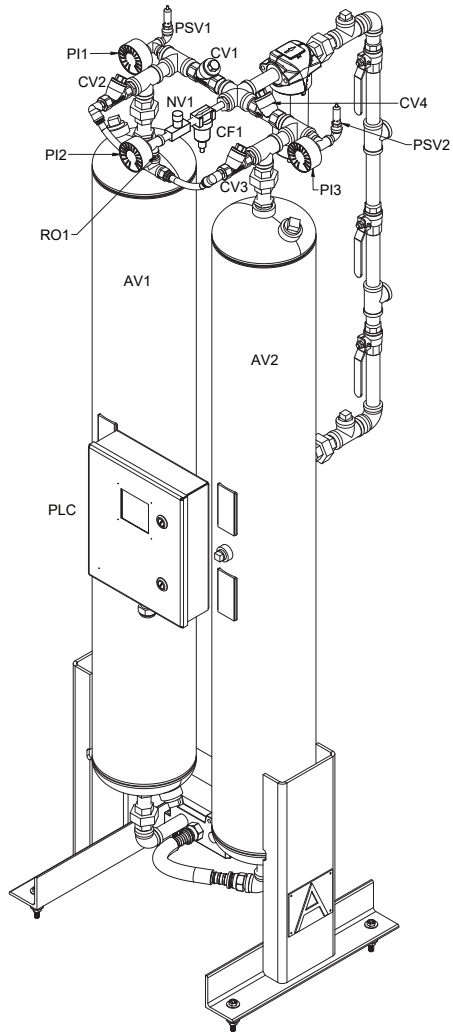

TW0055-BB11NNF-MAN

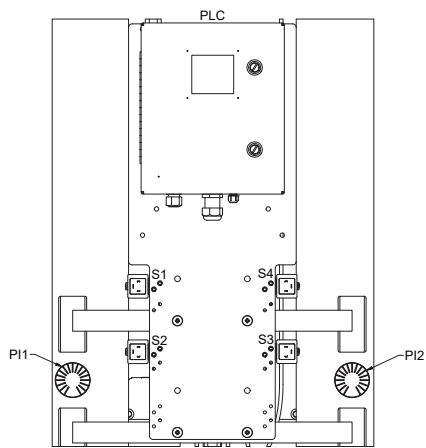
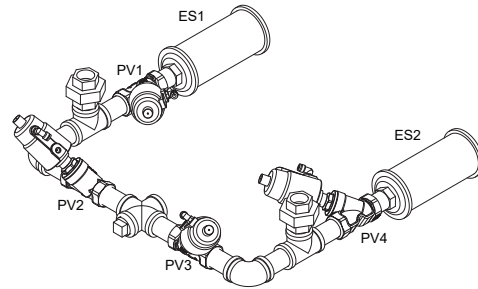
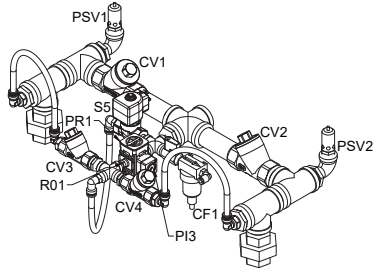
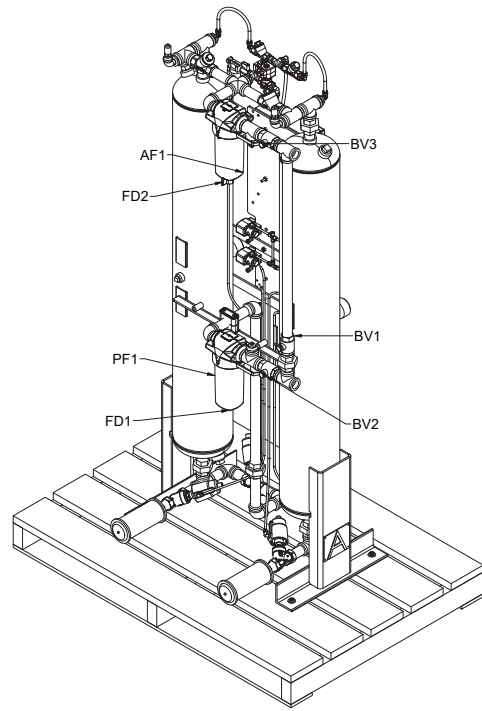
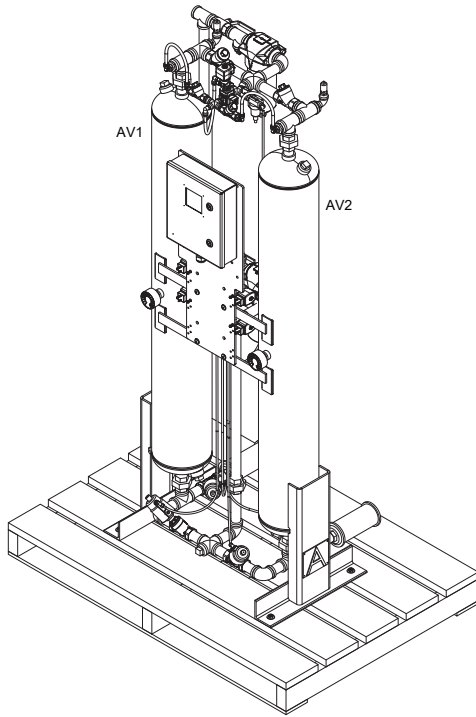

TW0100-BB11NNF-MAN



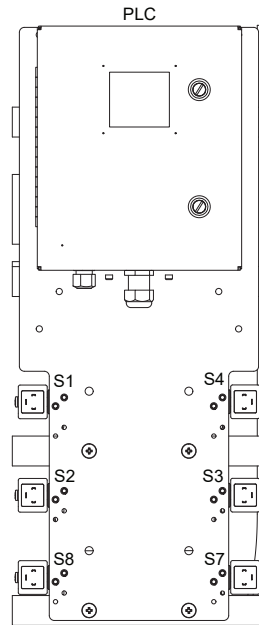
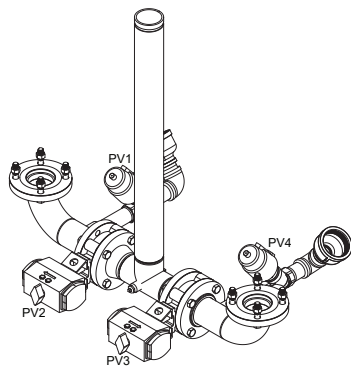
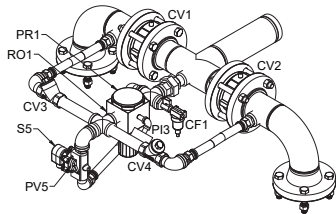
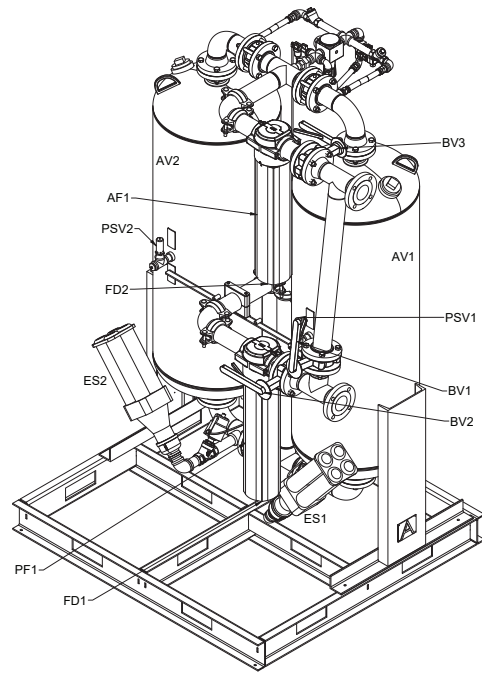
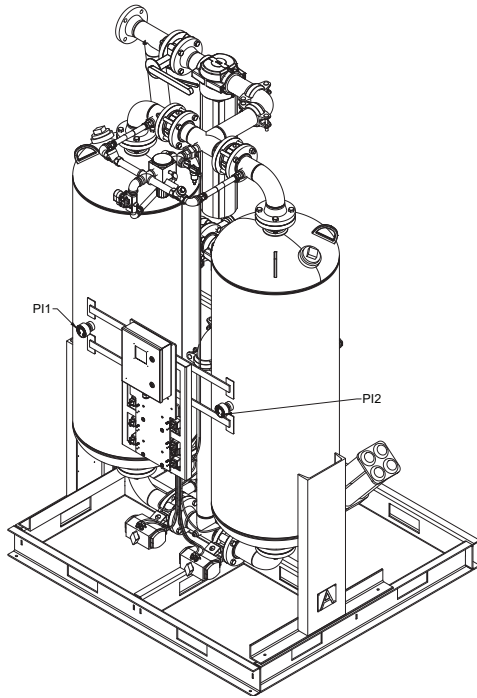

TW1200-BB11NNF-MAN

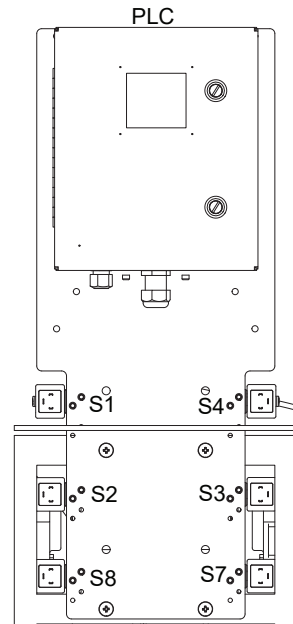
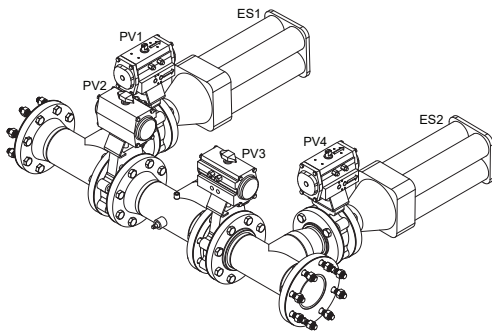
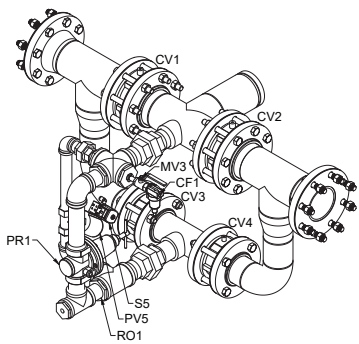
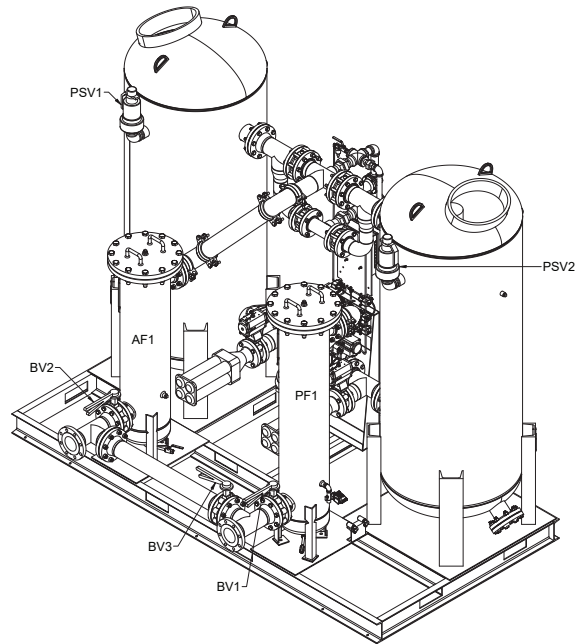
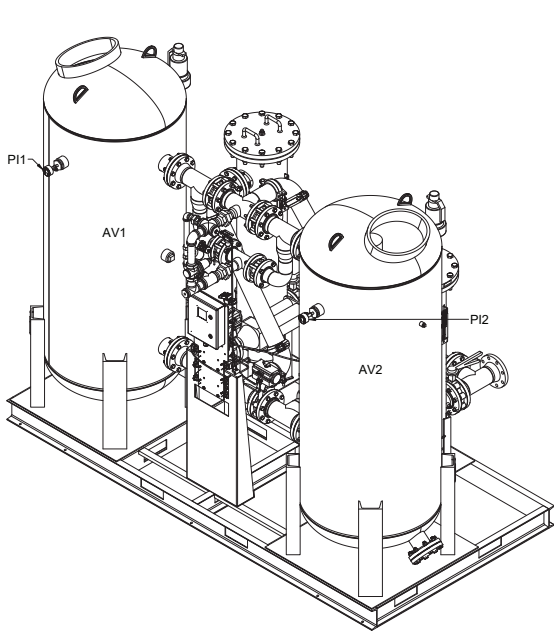

TW3000-BB11NNF-MAN





### 24. SCHEMATICS

#### 55 HEATLESS DRYER WITH BASIC CONTROLLER

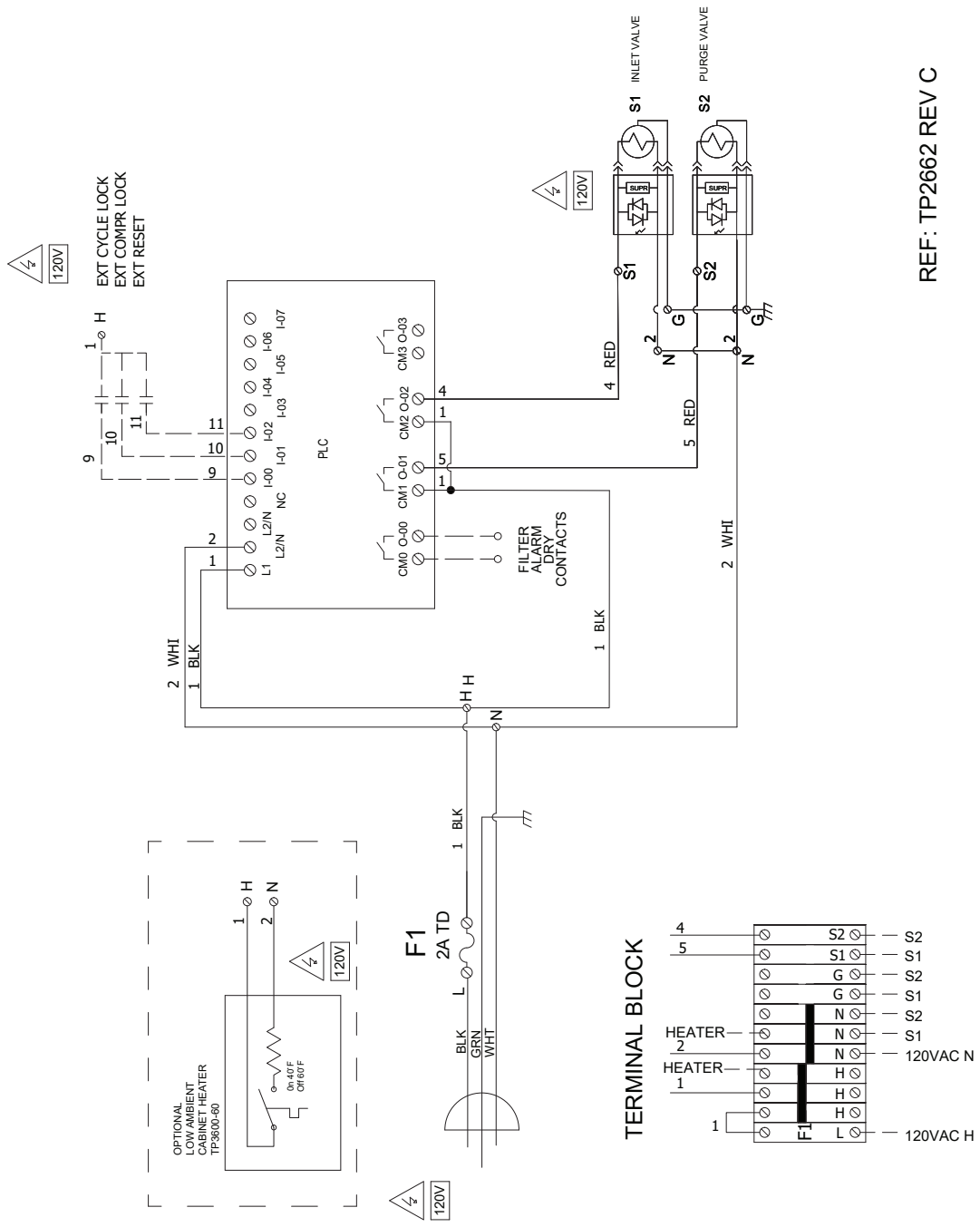

REF: TP2662 REV C



100-800 SCFM HEATLESS DRYER WITH BASIC CONTROLLER

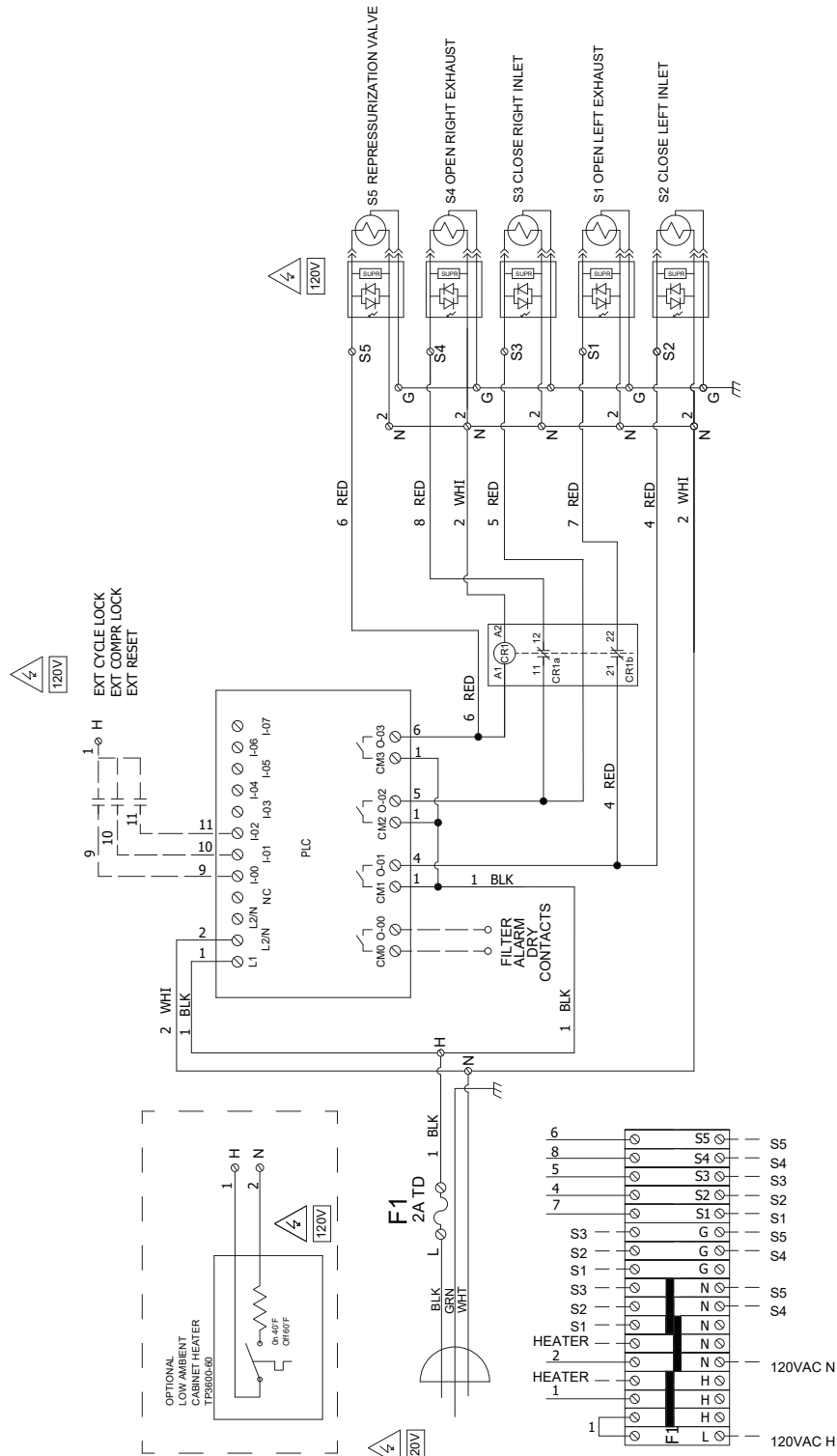

REF: TP2661 REV A



### 1000-3000 SCFM HEATLESS DRYER WITH BASIC CONTROLLER

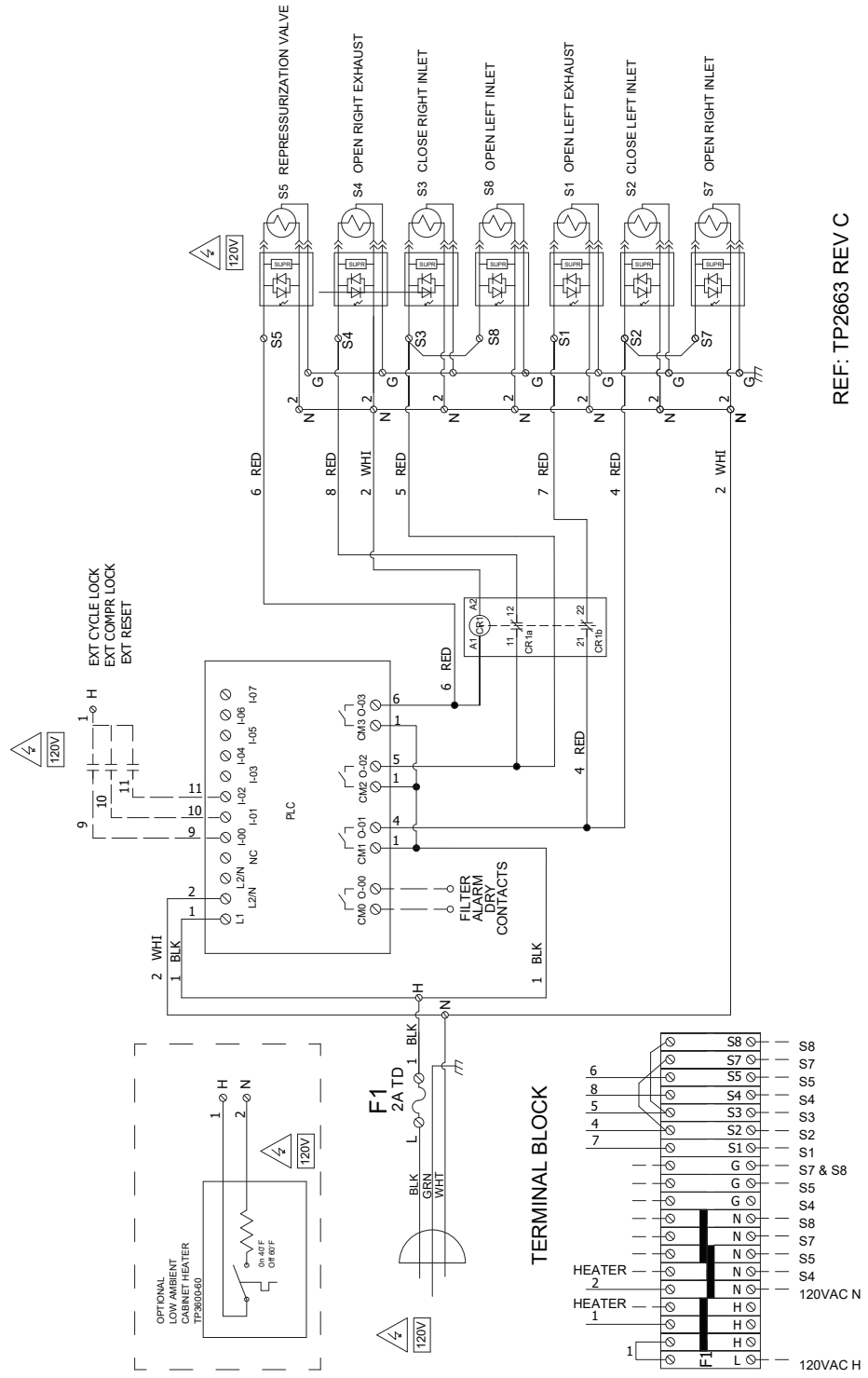

REF: TP2663 REV C



# 55 SCFM HEATLESS DRYER WITH BASIC+ CONTROLLER

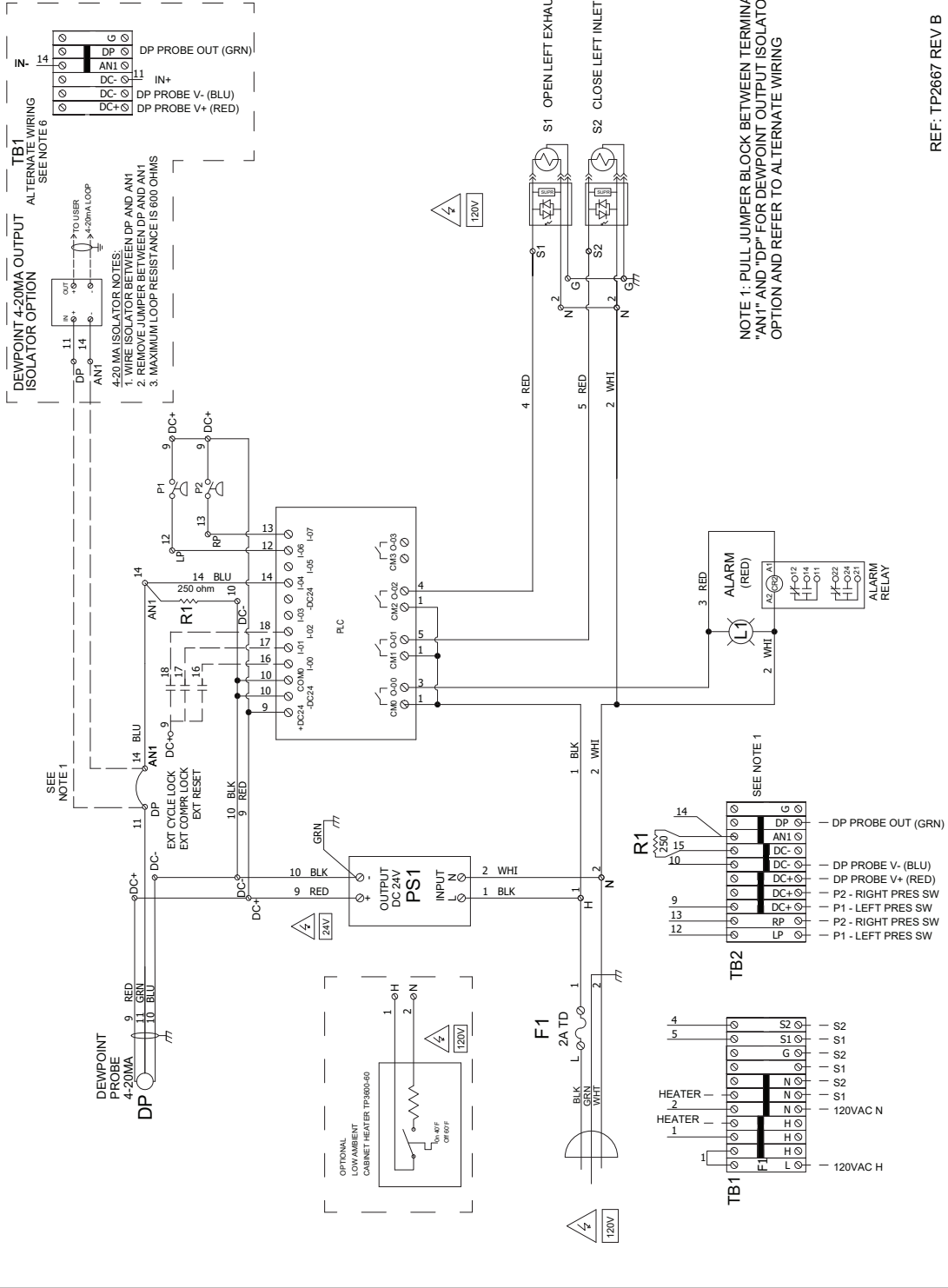

# 100-800 SCFM HEATLESS DRYER WITH BASIC+ CONTROLLER

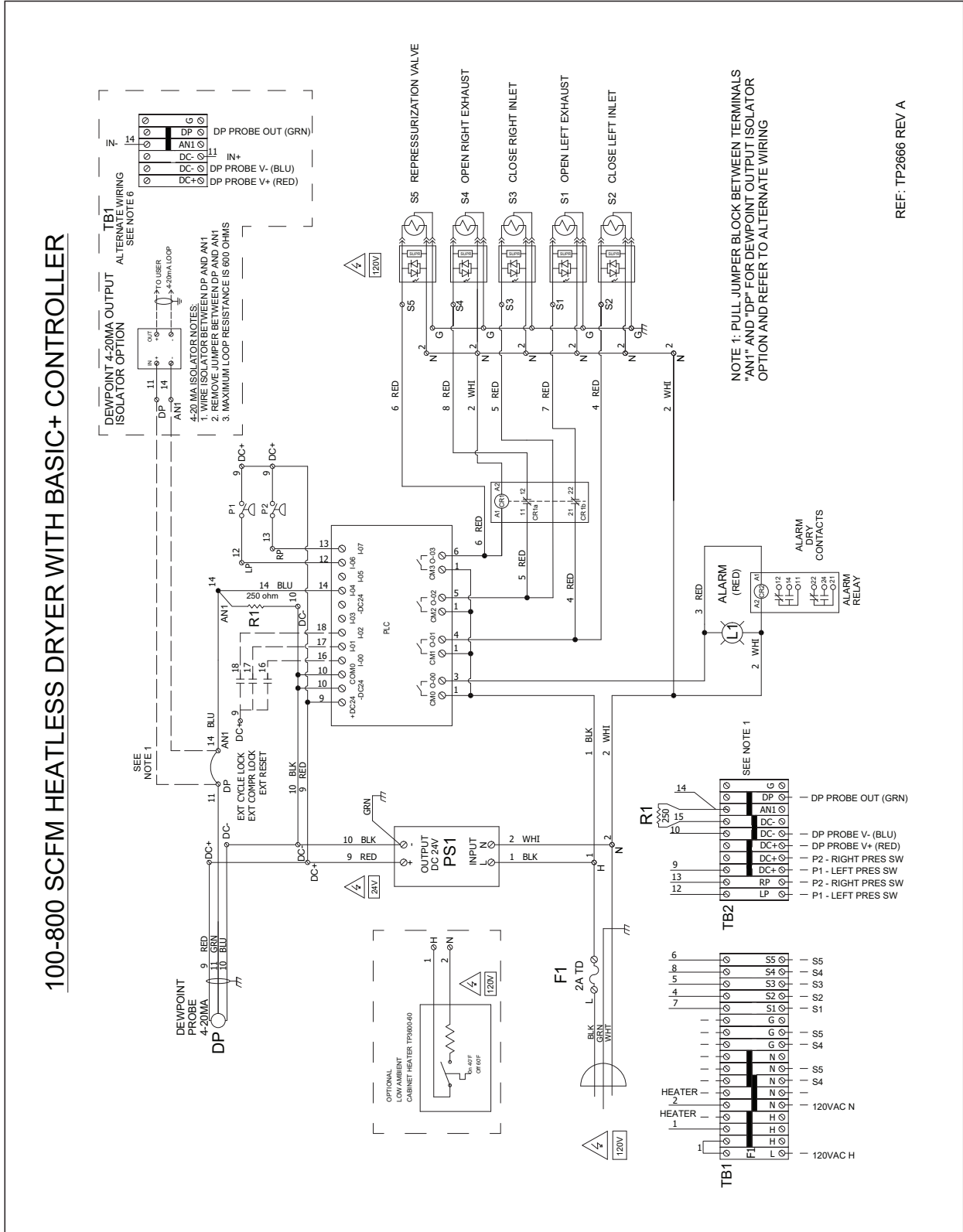

REF: TP2666 REV A



# 1000-3000 SCFM HEATLESS DRYER WITH BASIC+ CONTROLLER

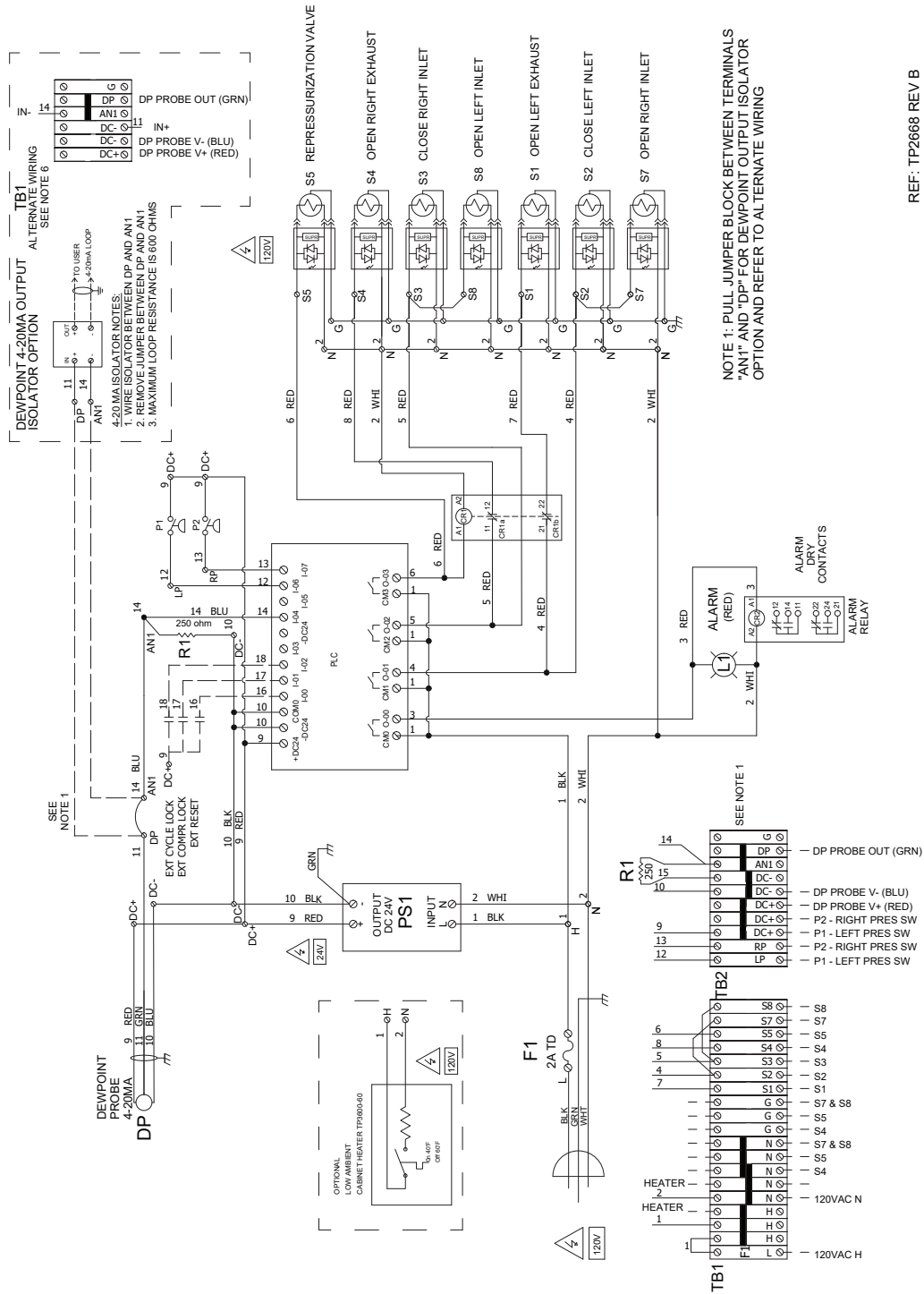

REF: TP2668 REV B



# 100-800 SCFM HEATLESS DRYER WITH ADVANCED CONTROLLER

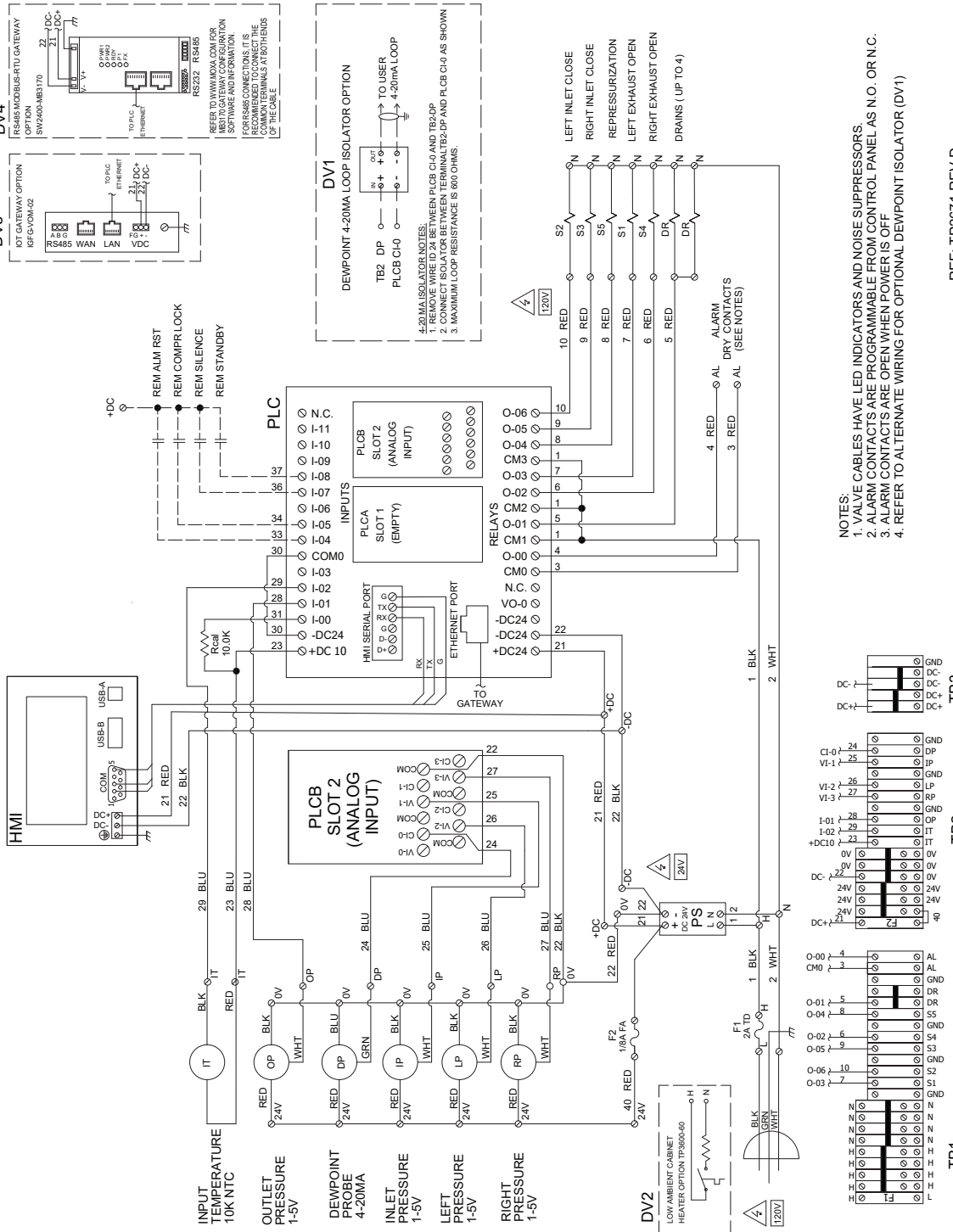

- NOTES:**
1. VALVE CABLES HAVE LED INDICATORS AND NOISE SUPPRESSORS.
  2. ALARM CONTACTS ARE PROGRAMMABLE FROM CONTROL PANEL AS N.O. OR N.C.
  3. ALARM CONTACTS ARE OPEN WHEN POWER IS OFF
  4. REFER TO ALTERNATE WIRING FOR OPTIONAL DEWPOINT ISOLATOR (DV1)

REF: TP2671 REV D



# 1000-3000 SCFM HEATLESS DRYER WITH ADVANCED CONTROLLER

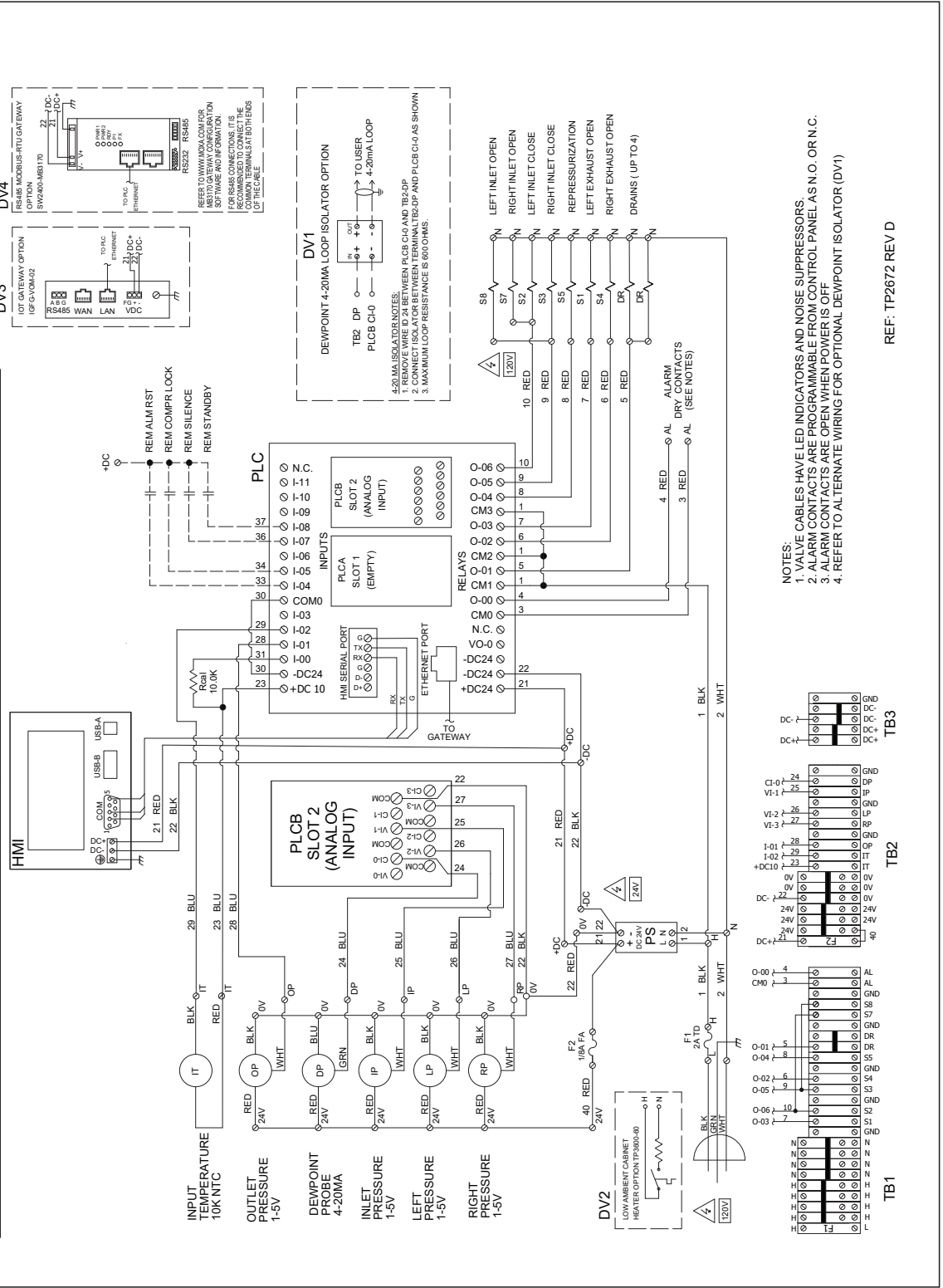

- NOTES:**
1. VALVE CABLES HAVE LED INDICATORS AND NOISE SUPPRESSORS.
  2. ALARM CONTACTS ARE PROGRAMMABLE FROM CONTROL PANEL AS N.O. OR N.C.
  3. ALARM CONTACTS ARE OPEN WHEN POWER IS OFF
  4. REFER TO ALTERNATE WIRING FOR OPTIONAL DEWPOINT ISOLATOR (DV1)

REF: TP2672 REV D





25. FLOW DRAWINGS

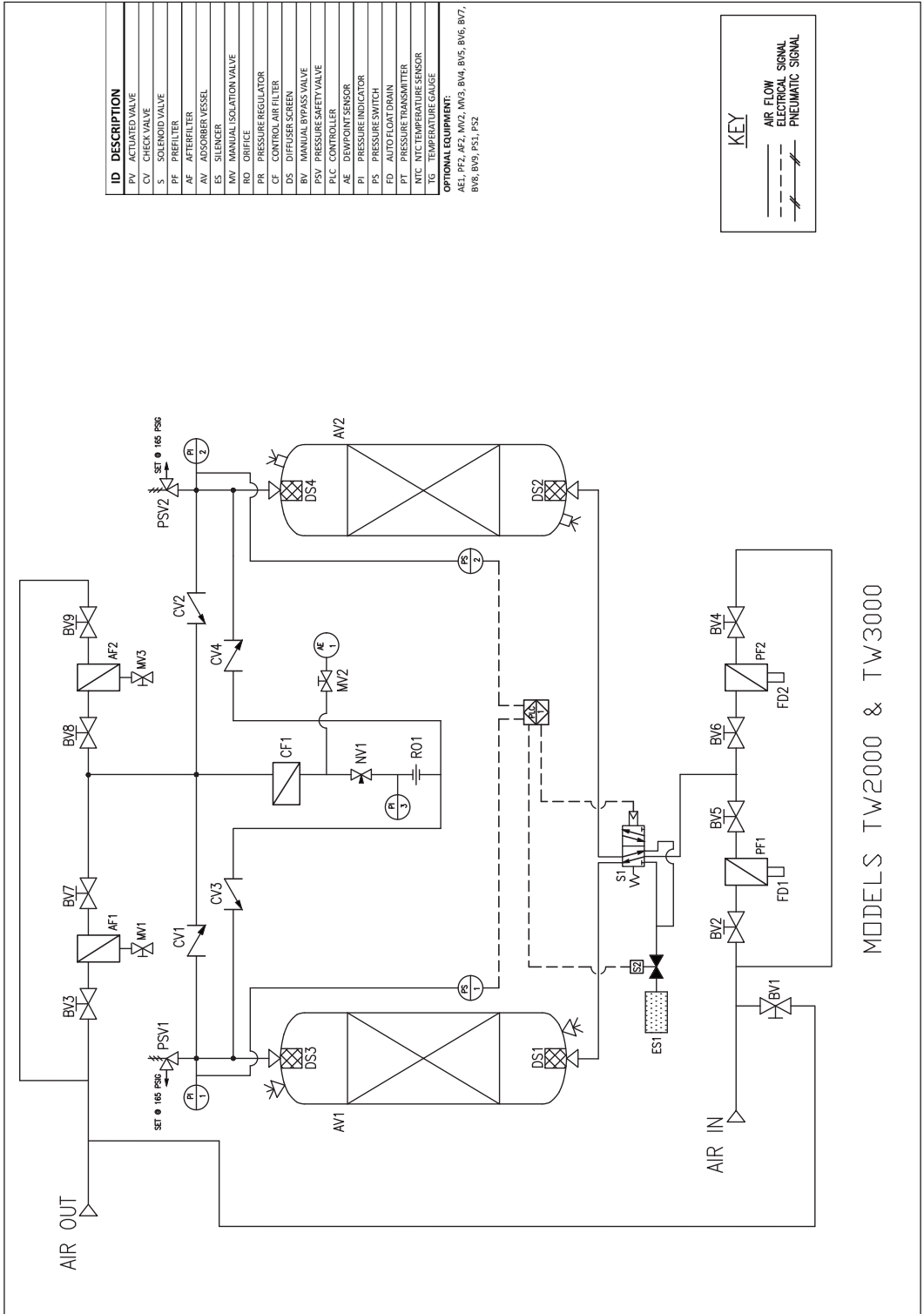

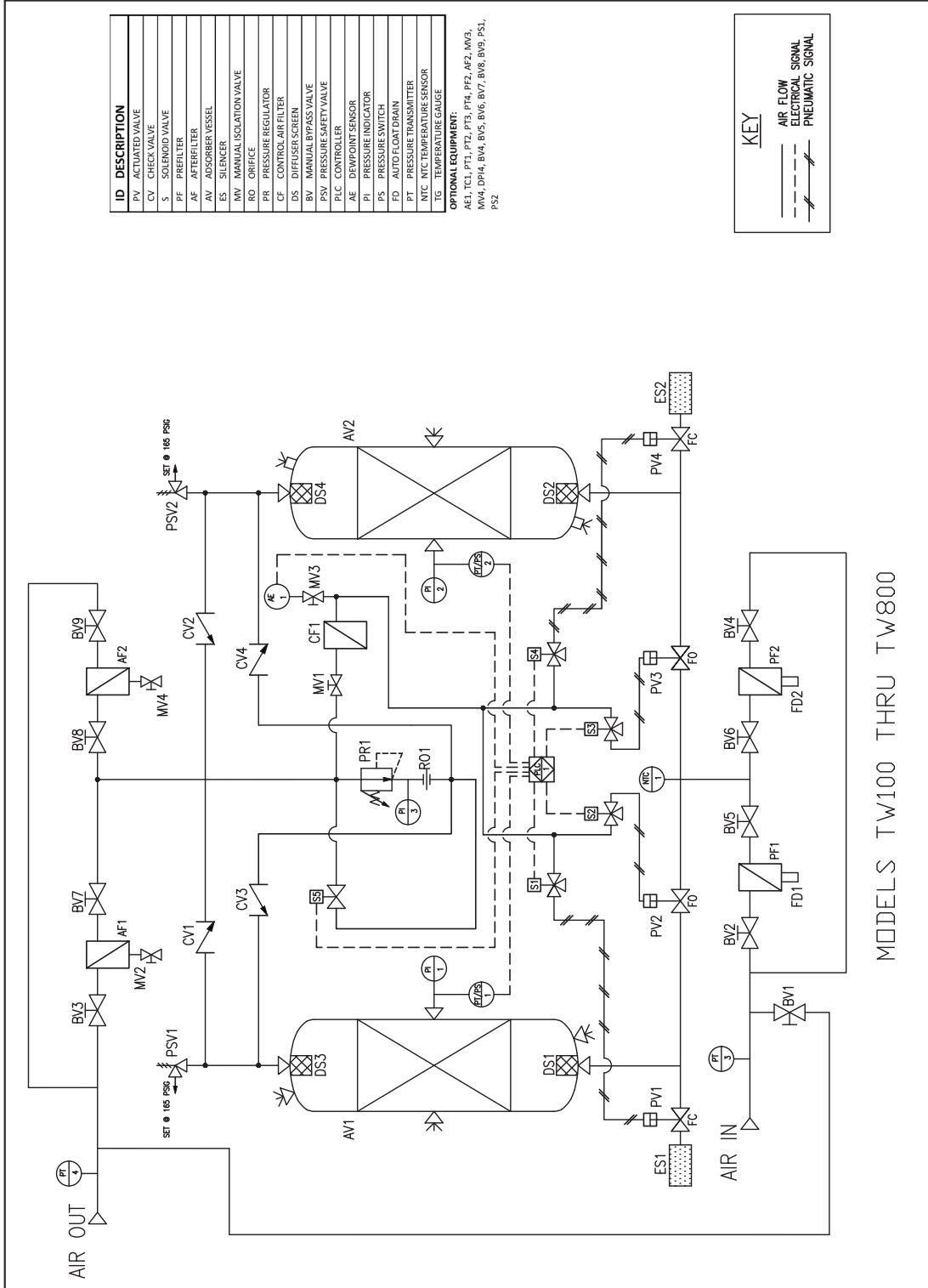

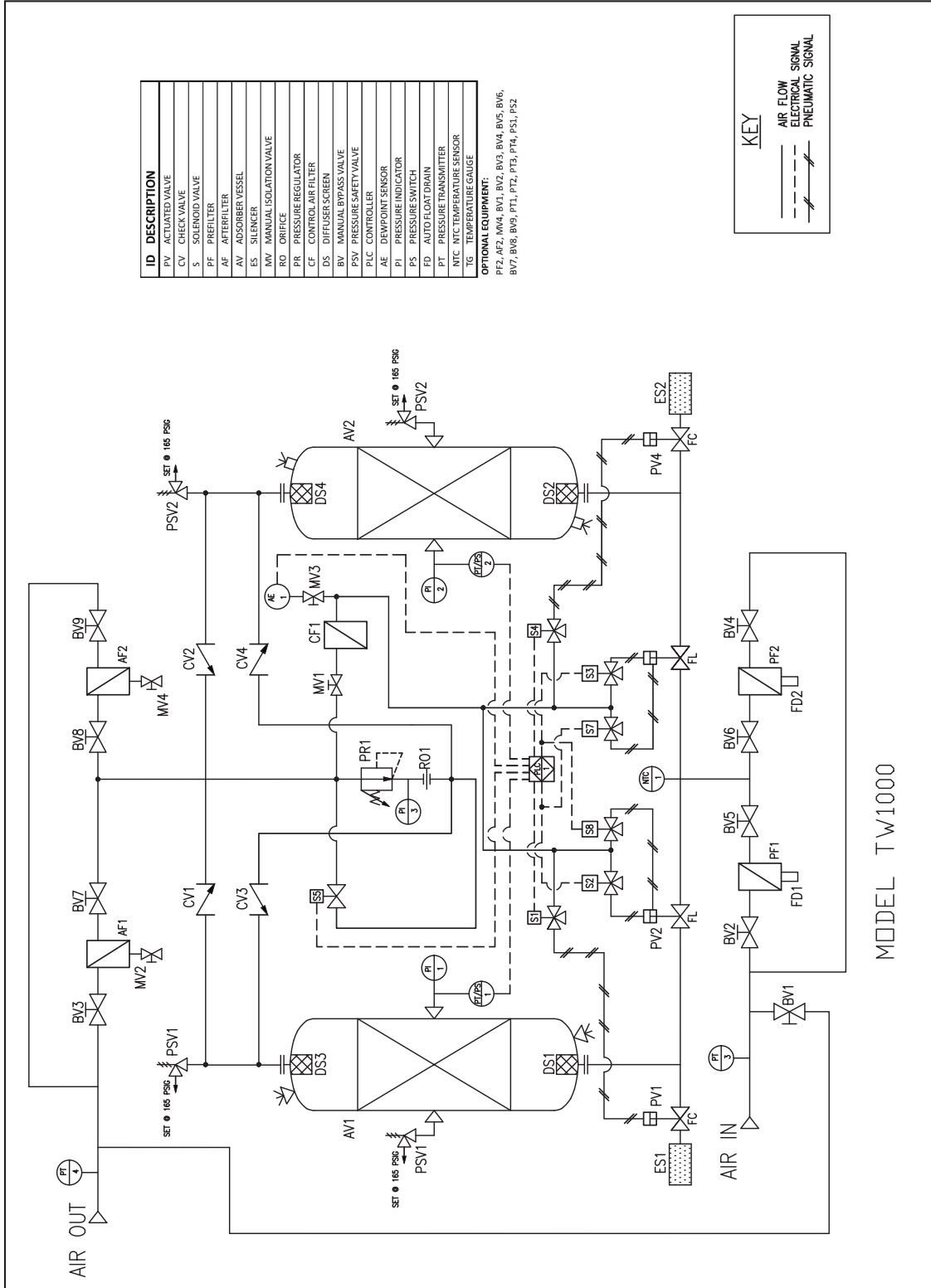

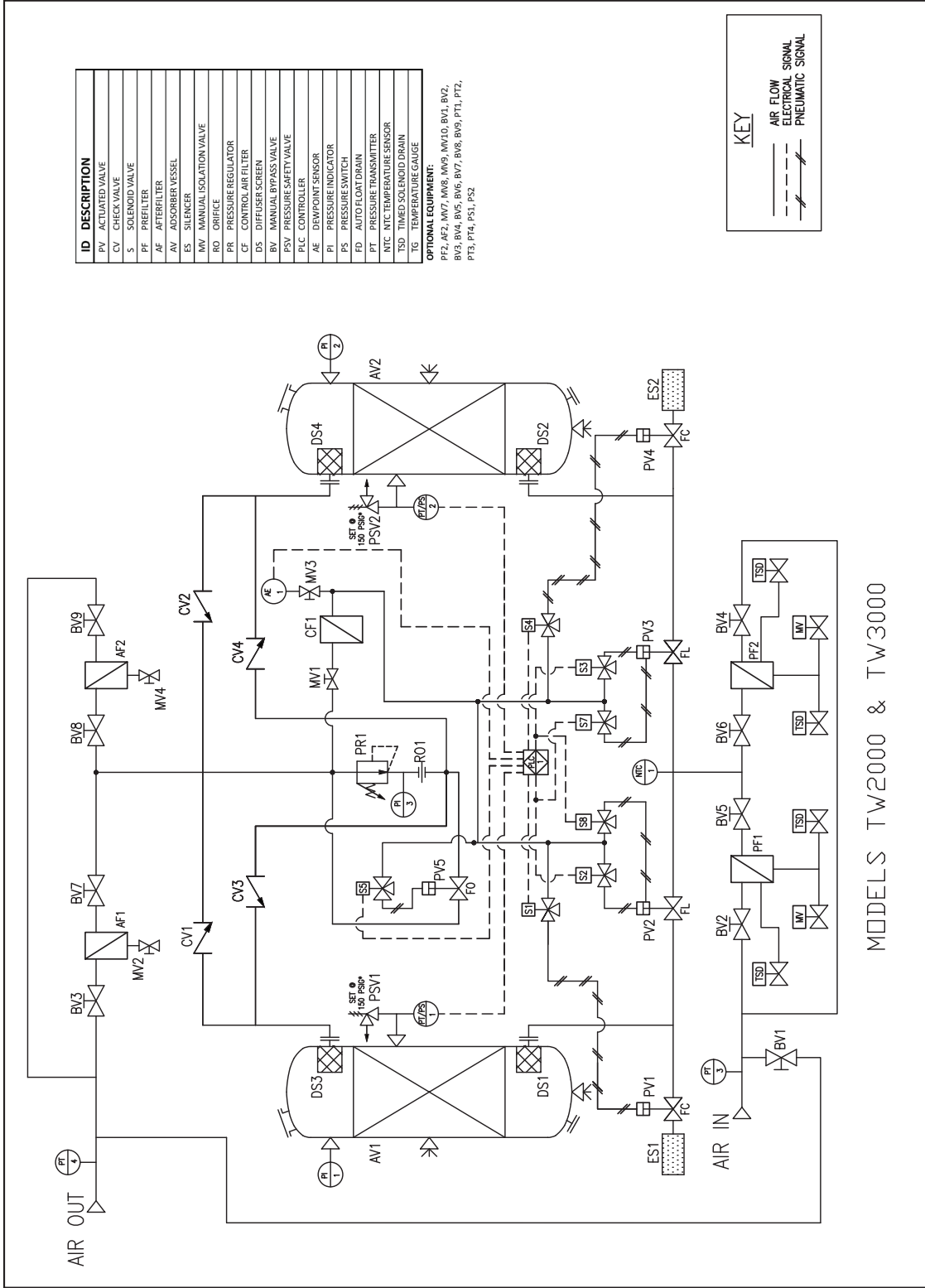

## 26. TROUBLESHOOTING

### **Dryer not operating; no lights on**

- Blown control fuse: replace fuse
- No power: apply correct power, verify quality of power source
- Controller inoperative: replace controller

### **Dryer not operating; lights on, dryer does not switch**

- Control air valve is closed: open control air valve; check condition of control air filter element
- Dryer in Compressor Lock or Dewpoint Demand mode: Disable Power Lock or Cycle Lock to go back to a standard timing cycle

### **High Outlet Dewpoint or Moisture Downstream**

- Dryer not cycling: see dryer not operating
- Incorrect purge rate: adjust purge setting to value specified on purge tag or manual
- Capacity of dryer exceeded: adjust inlet flow rate, inlet air temperature, and inlet air pressure to within specified operating conditions for the model
- Liquid water present at dryer inlet: check water level in separators, receivers, prefilters, and operation of associated y-strainers and auto drains. Check condition of filter elements or check differential pressure gauges
- Desiccant worn out, contaminated, or insufficient quantity: replace desiccant or add correct amount
- Reduced regeneration: see Back Pressure In Regenerating Tower
- Leaking bypass valve: replace valve
- Undried air from another source mixing downstream of dryer: remedy

### **Excessive Air Loss On Regenerating Tower**

- Purge pressure set too high: check specifications and adjust
- Re-pressurization solenoid leaking: repair, clean, or replace
- Inlet valve leaking or not functioning: See inlet valve not functioning
- Leaking or inoperative control solenoid: repair or replace
- Defective controller: repair or replace

### **Exhaust Valve On Drying or Re-pressurizing Tower Leaking**

- Valve dirty: clean valve
- Defective diaphragms or seals: rebuild valve or replace
- Leaking control solenoid: repair or replace

### **Excessive Pressure Drop**

- Prefilter or after filter fully saturated or collapsed: replace element
- Desiccant contaminated with oil: replace desiccant
- Excessive flow: reduce air flow rate to within product specs

**Unit Does Not Fully Pressurize**

- Purge rate too low: Adjust purge pressure setting
- Exhaust valve leaking: see exhaust valve leaking
- Purge orifice or repressurization valve plugged: clean

**Back Pressure In Regenerating Tower**

- Clogged mufflers: clean, repair, or replace
- Check valve leaking: clean, repair, or replace
- Purge flow too high: adjust purge pressure
- Leaking inlet valve: See inlet valve not functioning

**Inlet or Exhaust Valve Not Functioning**

- Bad seals or solenoid: rebuild valves with available kits or replace
- No output from controller: replace fuse or controller
- Valve dirty: rebuild or clean



# Parker Filtration Group

**Aerospace Filtration Division**  
Greensboro, North Carolina  
336 668 4444

**Bioscience & Water Filtration Division**  
Bioscience Filtration  
Oxnard, California  
877 784 2234

Water Purification  
Carson, California  
310 608 5600

**Engine Mobile Aftermarket Division**  
Kearney, Nebraska  
308 234 1951

**Engine Mobile Original Equipment Division**  
Modesto, California  
209 521 7860

**HVAC Filtration Division**  
Jeffersonville, Indiana  
866 247 4827

**Hydraulic & Fuel Filtration Division**  
Metamora, Ohio  
419 644 4311

**Industrial Gas Filtration & Generation Division**  
Lancaster, NY  
800 343 4048

**Industrial Process Filtration Division**  
Mineral Wells, Texas  
940 325 2575

**Bioscience Engineering Filtration Division EMEA**  
Birtley, United Kingdom  
+44 (0) 191 410 5121

**Engine Mobile Filtration Division EMEA**  
Dewsbury, United Kingdom  
+44 (0) 1924 487 037

**Gas Separation & Filtration Division EMEA**  
Team Valley, United Kingdom  
+44 (0) 191 402 9000

**Gas Turbine Filtration Division**  
Alton, United Kingdom  
+44 (0) 1420 541188

**Hydraulic & Industrial Filtration Division EMEA**  
Arnhem, Netherlands  
+31 (0) 26 376 0376

**Australia Filtration Division**  
Castle Hill, Australia  
+61 2 9634 7777

**China Filtration Division**  
Shanghai, China  
+86 21 2067 2067

**India Filtration Division**  
Chennai, India  
+91 22 4391 0700

**Korea Filtration Division**  
Hwaseon City, Korea  
+82 31 359 0852

**Latin America Filtration Division**  
Sao Paulo, Brazil  
+55 12 4009 3500



© 2024 Parker Hannifin Corporation. Product names are trademarks or registered trademarks of their respective companies. IOM\_PKR\_TW0055-TW3000\_Rev-D\_072024



Parker Hannifin Corporation  
**Industrial Gas Filtration and Generation Division**  
4087 Walden Avenue  
Lancaster, NY 14086  
phone 800 343 4048  
[www.parker.com/igfg](http://www.parker.com/igfg)